

**Statement of Principles, Criteria and
Verification Procedures on Driver
Interactions with Advanced In-
Vehicle Information and
Communication Systems**

**Including
2006 Updated Sections**

Driver Focus-Telematics Working Group

June 26, 2006

Table of Contents

Table of Contents	1* ¹
Preface	6*
Background	7*
Definition of Objectives	9*
Scope	11*
Existing Requirements	13*
Section 1. Installation Principles	13*
Principle 1.1	13*
The system should be located and fitted in accordance with relevant regulations, standards, and the vehicle and component manufacturers’ instructions for installing the systems in vehicles.	
Rationale	13*
Criterion/Criteria	13*
Verification Procedures	14
Examples	14
Principle 1.2	14
No part of the system should obstruct the driver’s field of view as defined by applicable regulations.	
Rationale	14
Criterion/Criteria	14
Verification Procedures	14
Examples	15
Principle 1.3	15
No part of the physical system should obstruct any vehicle controls or displays required for the driving task.	
Rationale	15
Criterion/Criteria	15
Verification Procedures	15
Examples	15*
Principle 1.4	16*
Visual displays that carry information relevant to the driving task and visually-intensive information should be positioned as close as practicable to the driver’s forward line of sight.	
Rationale	16*
Criterion/Criteria	16*
Verification Procedures	31*
Examples	36*

¹ * 2006 Updated Sections

Principle 1.5	38*
Visual displays should be designed and installed to reduce or minimize glare and reflections.	
Rationale	38*
Criterion/Criteria.....	38*
Verification Procedures	38*
Examples.....	39*
Section 2. Information Presentation Principles.....	39*
Principle 2.1	39
Systems with visual displays should be designed such that the driver can complete the desired task with sequential glances that are brief enough not to adversely affect driving	
Rationale	39
Criterion/Criteria.....	40
Verification Procedures	46
Examples.....	55
Principle 2.2	62*
Where appropriate, internationally agreed upon standards or recognized industry practice relating to legibility, icons, symbols, words, acronyms, or abbreviations should be used. Where no standards exist, relevant design guidelines or empirical data should be used	
Rationale	62*
Criterion/Criteria.....	62*
Verification Procedures	62*
Examples.....	63*
Principle 2.3	63*
Available information relevant to the driving task should be timely and accurate under routine driving conditions	
Rationale	63*
Criterion/Criteria.....	63*
Verification Procedures	64*
Principle 2.4	64*
The system should not produce uncontrollable sound levels liable to mask warnings from within the vehicle or outside or to cause distraction or irritation.	
Rationale	64*
Criterion/Criteria.....	64*
Verification Procedures	64*
Examples.....	64*

Section 3. Principles on Interactions with Displays/Controls	64*
Principle 3.1	67*
The system should allow the driver to leave at least one hand on the steering control.	
Rationale	67*
Criterion/Criteria	68*
Verification Procedures	68*
Examples	69
Principle 3.2	69
Speech-based communication systems should include provision for hands-free speaking and listening. Starting, ending, or interrupting a dialog, however, may be done manually. A hands-free provision should not require preparation by the driver that violates any other principle while the vehicle is in motion	
Rationale	69
Criterion/Criteria	70*
Verification Procedures	70*
Examples	70*
Principle 3.3	70*
The system should not require uninterruptible sequences of manual/visual interactions. The driver should be able to resume an operator-interrupted sequence of manual/visual interactions with the system at the point of interruption or at another logical point in the sequence.	
Rationale	70*
Criterion/Criteria	71*
Verification Procedures	71*
Examples	72*
Principle 3.4	72*
In general (but with specific exceptions) the driver should be able to control the pace of interaction with the system. The system should not require the driver to make time-critical responses when providing input to the system	
Criterion/Criteria	72*
Verification Procedures	74*
Principle 3.5	74*
The system's response (e.g. feedback, confirmation) following driver input should be timely and clearly perceptible.	
Rationale	74*
Criterion/Criteria	75
Verification Procedures	75

Principle 3.6	75
Systems providing non-safety-related dynamic (i.e. moving spatially) visual information should be capable of a means by which that information is not provided to the driver.	
Rationale	75
Criterion/Criteria.....	76
Verification Procedures	76
Section 4. System Behavior Principles	77*
Principle 4.1	77*
Visual information not related to driving that is likely to distract the driver significantly (e.g., video and continuously moving images and automatically-scrolling text) should be disabled while the vehicle is in motion or should be only presented in such a way that the driver cannot see it while the vehicle is in motion.	
Rationale	77*
Criterion/Criteria.....	78
Verification Procedures	78
Examples.....	78
Principle 4.2	78
(a) System functions not intended to be used by the driver while driving should be made inaccessible for the purpose of driver interaction while the vehicle is in motion.	
(b) The system should clearly distinguish between those aspects of the system, which are intended for use by the driver while driving, and those aspects (e.g. specific functions, menus, etc) that are not intended to be used while driving	
Rationale	78
Criterion/Criteria.....	79
Verification Procedures	79
Principle 4.3	79
Information about current status, and any detected malfunction, within the system that is likely to have an adverse impact on safety should be presented to the driver.	
Rationale	79
Criterion/Criteria.....	79
Verification Procedures	80
Section 5. Principles on Information About the System.....	80*
Principle 5.1	80*
The system should have adequate instructions for the driver covering proper use and safety-relevant aspects of installation and maintenance.	

Principle 5.2	80*
Safety instructions should be correct and simple.	
Principle 5.3	80*
System instructions should be in a language or form designed to be understood by drivers in accordance with mandated or accepted regional practice.	
Principle 5.4	80*
The instructions should distinguish clearly between those aspects of the system that are intended for use by the driver while driving, and those aspects (e.g. specific functions, menus, etc) that are not intended to be used while driving	
Principle 5.5	80*
Product information should make it clear if special skills are required to use the system or if the product is unsuitable for particular users.	
Principle 5.6	80*
Representations of system use (e.g. descriptions, photographs, and sketches) provided to the customer with the system should neither create unrealistic expectations on the part of potential users, nor encourage unsafe or illegal use.	
Rationale	80*
Annex #1 Glossary of Terms	82*

Preface

When drivers interact with in-vehicle information and communication systems (telematics devices) that have visual-manual interfaces there is the potential for distraction of the driver from the driving task. This “Statement of Principles, Criteria, and Verification Procedures on Driver Interactions with Advanced In-Vehicle Information and Communication Systems” document, commonly-known as Driver Focus – Telematics Guidelines (hereafter, Guidelines), was developed as a tool for designing telematic systems that minimize the potential for driver distraction during this visual-manual interaction while the vehicle is in motion.

The intended application of the Guidelines is to provide criteria and evaluation procedures for use by automotive manufacturers and manufacturers of telematic devices during product development. It is presumed that those applying the Guidelines have the technical knowledge of the products under evaluation, as well as access to resources necessary to carry out the specified evaluation procedures. To the extent that one uses this document for post facto evaluation, for certain test and assessment determinations, appropriate product knowledge and test facilities are needed, as is the case for many federally developed safety standards. These Guidelines are not suitable as the basis for an informal inspection-based evaluation. While scientifically based, these Guidelines do not represent a self-contained academic work.

Alliance of Automobile Manufacturers members have voluntarily committed to design production vehicles to these Guidelines within specific designated timeframes.

The Guidelines are “a work in progress” and will continue to be refined as resources and scientific support become available. There is extensive ongoing relevant research in the area of driver distraction and workload management and as new information becomes available the document will need to be reviewed for possible updating.

These guidelines does not address spoken dialogue (i.e., voice-activated) devices. Future work will be undertaken to develop and issue guidelines that address voice-activated systems.

By virtue of their different purpose, these guidelines do not to apply to driver assistance systems and associated HMI elements such as audio/visual alerts and cues, haptic displays and cues and head-up displays that may intentionally be used to attract the driver’s attention. As recognized by the ESoP draft dated June 2005, Advanced Driver Assistance Systems (ADAS) are “fundamentally different and require additional considerations in terms of Human Machine interaction.”

Background

On July 18, 2000 the National Highway Traffic Safety Administration held a public meeting to address growing concern over motor vehicle crashes and driver use of cellular telephones and other electronic distractions present in the vehicle. At that meeting, NHTSA challenged industry to respond to the rising concern in this area.

As a result of this challenge, the Alliance of Automobile Manufacturers agreed to develop a “best practices” document to address essential safety aspects of driver interactions with future in-vehicle information and communications systems. These systems, also known as “telematic” devices, include such items as cellular telephones, navigation systems or Internet links. In December 2000, the Alliance submitted to NHTSA a comprehensive list of draft principles related to the design, installation and use of future telematic devices. This list of draft principles was based, in large part, on the European Commission recommendations of December 21, 1999, on safe and efficient in-vehicle information and communication systems (2000/53/EC0). At that time, the Alliance agreed to seek input from experts and interested parties to develop the principles into a more comprehensive document including more fully define performance criteria and verification procedures.

A work group of experts, Alliance members and other interested parties was formed in March, 2001 under the Chairmanship of Mr. Donald Bischoff and included participants from the Intelligent Transportation Society of America, the Society of Automotive Engineers, the Consumer Electronics Association, the American Automobile Association, the National Safety Council, the Association of International Automobile Manufacturers, and the Truck Manufacturers Association. The NHTSA and Transport Canada participated as observers in the process and the Insurance Institute for Highway Safety was a corresponding member.

These design guidelines focus on light vehicles and are intended to be used by both original equipment manufacturers and the aftermarket. These guidelines are limited to safety aspects of human machine interface (HMI) for:

- ❑ “new” information and communication technology and devices with visual and manual/visual interfaces
- ❑ features and functions designed to be used by a driver while driving (vehicle speed \geq 5 mph)
- ❑ under “routine driving conditions”

The document that follows is organized according to twenty-four principles divided into five sections. Elaborations have been drafted for each of the principles. These elaborations include specific criterion/criteria, technical justification, verification procedures, and illustrative examples on how they satisfy the principle.

Furthermore, there is extensive ongoing relevant research in the area of driver distraction and workload management and as new information becomes available, this document will need to be reviewed for possible updating to reflect the current state-of-knowledge.

While this document is intended to represent current best practice in understanding the safety aspects of HMI, it must be remembered that, as always, the driver retains the primary responsibility for ensuring safe operation of the vehicle under all operating conditions.

Definition of Objectives

This Statement of Principles is developed as a voluntary industry guideline to address essential safety aspects to be taken into account for the human machine interface (HMI) for driver interactions with future in-vehicle information and communication systems equipped with visual or manual/visual interfaces. It specifically does not apply to voice-activated systems or to systems using head-up displays.

This Statement of Principles will be of particular use to light vehicle and telematics manufacturers when they have to consider the safety implications of HMI design. Design and installation issues related to devices designed to be used by a driver while the vehicle is in motion are the main concern of this Statement of Principles and therefore relate to the following critical issues:

- ❑ design and location of information and communication systems in such a way that their use is compatible with the driving task under routine driving conditions;
- ❑ presentation of information so as not to impair the driver's visual, cognitive, or auditory ability to safely perform the driving task under routine driving conditions;
- ❑ design of system interaction such that under all reasonable circumstances the driver is able to maintain safe control of the vehicle, feels comfortable and confident with the system and is ready to respond safely to unexpected occurrences; and
- ❑ presence, operation, or use of a system specified in such a way that it does not adversely interfere with displays or controls required for the driving task and for road safety.

In order not to create unnecessary obstacles or constraints to the innovative development of products, the Statement of Principles is expressed mainly in terms of performance- based goals to be reached by the HMI. Consistent with this objective the system should be designed:

- ❑ to minimize adverse effects on driving safety;
- ❑ to enable the driver to maintain sufficient attention to the driving situation while using the system; and
- ❑ to minimize driver distraction and not to visually entertain the driver while driving.

This Statement of Principles assumes that manufacturers will follow rigorous process standards when developing products in accordance with these guidelines.

Vehicle manufacturers already have robust product development processes that ensure the integrity of their vehicle development programs from concept to production.

Manufacturers of telematics devices who may lack such a process control system should implement recognized industry process standards. Examples of such recognized process standards include:

- Auto Industry Action Group's (AIAG's) "Advanced Product Quality Planning (APQP) and Control Plan Reference Manual" issued in 1994
- VDA "Quality Assurance of Supplies" edition 1998, VDA "Quality Assurance prior to Serial Application, Part 1" edition 1996
- VDA "Quality Assurance before series production, Part 2" edition 1996
- VDA "Quality Assurance prior to Serial Application, Part 3" edition 1998
- ISO/TS 16949 "Quality management systems - Particular requirements for the application of ISO 9001:2000 for automotive production and relevant service parts organizations" (2002-03-01)

Scope

This Statement of Principles is concerned with advanced information and communication systems and the visual-manual interaction of the driver while the vehicle is in motion. For example (not exhaustive), navigation, phoning, messaging or interactive information services of the types listed below should be evaluated utilizing these guidelines.

Navigation	Destination Entry Route Following
Phoning ²	Incoming call management initiating and terminating call Conferencing Walkie Talkie – like services
Messaging	Caller ID Reminders Paging Short Message Services (SMS) Email Instant Messaging
Interactive Information Services	Stock Quotes Real-time Traffic advisory – on request Horoscopes Headlines Advertising Address Book Database Search (e.g. internet search) Financial services Directory

These Principles are not intended to apply to conventional information or communication systems, nor to collision warning or vehicle control systems. These principles are not a substitute for regulations and standards that should be respected and used by suppliers and manufacturers of in-vehicle information and communication systems. In the event of any conflict between these principles and applicable regulations, the regulations take precedence.

In this context it is helpful to clarify what is meant by “conventional” systems. Following is a list of what currently would be considered conventional information or communication systems:

AM radio	CD
FM radio	MP3
Satellite radio	RDS
Cassette	Vehicle Information Center ³

² The visual-manual aspects of phoning are covered by these principles

³ A vehicle information center displays information about vehicle systems status (e.g., trip information, door ajar, fuel economy, etc.); it does not display information from off-board the vehicle

In addition to these listed information and communication systems, other conventional controls and displays such as HVAC, speedometer, gauges, etc. are also out-of-scope.

While these “conventional” systems would not be subject to the requirements of this document, the direction of future driver interfaces may be to combine multiple functions into a single integrated system. As these “conventional” systems become integrated with any in-scope capability such as navigation, phoning, messaging, or interactive information services, consideration should be given not to increase the workload of these conventional systems by virtue of integrating them with in-scope systems.

The main topics of this Statement of Principles are installation, information presentation, interaction with displays and controls, system behavior and information about the system. For the purpose of this Statement of Principles ‘the system’ includes all functions and components with which the manufacturer intends the driver to interact while driving, whether stand alone or integrated into the vehicle or another system.

These principles are applicable, unless otherwise indicated:

- ❑ whether or not the system is directly related to the driving task or whether the system is portable or permanently installed. This is intended to clarify that the guidelines apply to all systems/functions designed for use in a motor vehicle. This would include, for example, a portable navigation system designed for automotive use, as well as a personal digital assistant (PDA) enabled to be viewed or accessed through the vehicle's driver interface; or
- ❑ to original equipment as well as to third party devices or functions (including software and data) intended to be usable by the driver while the vehicle is in motion.

It should be noted that the following verification procedures will be undertaken only for those system features and prompts/messages that are deemed by engineering analysis to represent expected “real-world” performance from the standpoint of compliance with any specific principle. System features and prompts/messages deemed through engineering analysis to be compliant with these principles need not be verified by actual testing.

These principles have been formulated to consider the design and installation of individual systems. Where more than one system is present within a vehicle, they should ideally be coordinated to minimize demands on the driver in accordance with this Statement of Principles.

The Statement of Principles does not cover aspects of information and communication systems not related to HMI, such as electrical characteristics, material properties, system performance, and legal aspects.

The responsibilities of the driver related to safe behavior while driving and interacting with these systems remain unchanged. The driver retains the primary responsibility for ensuring safe operation of the vehicle under all operating conditions.

Existing Requirements

This Statement of Principles is not a substitute for regulations and standards which should always be respected and used by suppliers and manufacturers of in-vehicle information and communication systems. In the event of any conflict between these principles and applicable regulations, the regulations take precedence.

All regulations and standards are subject to revision, and users of this Statement of Principles should apply the most recent edition of any applicable regulation or standard.

Generally, it will be clear where the responsibility lies among manufacturers, suppliers, or installers. For example, these principles are applicable to any/all device interfaces and functionalities ported into the vehicle using vehicle manufacturers' connectivity provisions for portable devices (e.g., in-vehicle integrated display of certain phone information during hands-free operation of portable phone connected to vehicle manufacturer's provided docking station). Device manufacturers will be responsible for functions not ported or linked into vehicle architecture as intended by the vehicle manufacturer. Where the responsibility rests with more than one party, those parties are encouraged to use the principles as a starting point to explicitly confirm their respective roles.

Section 1.0 Installation Principles

The principles and criteria in this section address the packaging and installation of a system into the vehicle in a way that facilitates appropriate placement relative to the forward field of view and to minimize interference with driving that could result from inappropriate placement (such as glare, obstruction of sight lines to the road or regulated displays, or obstruction of reach to driving-related controls).

1.1 The system should be located and fitted in accordance with relevant regulations, standards, and the vehicle and component manufacturers' instructions for installing the systems in vehicles.

Rationale:

Manufacturers design products for an intended use and in conformity with appropriate regulations and standards. If their installation instructions or any relevant standards or regulations are not followed, the installer may cause the system to be used by the driver in a way which was not intended by the manufacturer and this could have negative safety consequences. Following this Principle increases the possibility of the system being easy to access without excessive body movement and minimizes the possibility that the device could interfere with other vehicle systems and components, whether physically, electrically, or electro-magnetically.

Criterion/Criteria:

System will be located and fitted to conform to applicable standards, e.g., SAE, ISO, and regulations, e.g., FMVSS, CMVSS, and manufacturer-specific installation instructions.

Verification Procedure:

Design to conform and validate by appropriate means as may be specified by relevant standards or regulations or manufacturer-specific instructions.

Examples:

Good: A satellite radio fitted fully in accordance with all required standards, regulations, and manufacturers' instructions.

Bad: A traffic information display fixed to the instrument panel partially obstructing the air bag cover, or connected to the electrical system in a manner that causes another vehicle system to malfunction.

1.2 No part of the system should obstruct the driver's field of view as defined by applicable regulations.

Rationale:

Successful performance of the driving task is based upon the acquisition of visual information about the local road and traffic environment. In acceptance of this fact, safety regulations ensure that motor vehicles provide the driver with an adequate external field of view out of the vehicle from the driver's seat. Additional systems must not compromise this basic design provision.

Criterion/Criteria:

When installed in a vehicle no part of the system should be in a physical position such that the driver's field of view of the roadway is affected to the extent applicable compliance with safety standards and regulations cannot be accomplished.

Relevant US and Canadian motor vehicle safety regulations include:

- 101 – Control Location, Identification and Illumination
- 103 – Windshield Defroster and Defogger System
- 104 – Windshield Wiping and Washing System
- 111- Rear View Mirrors

Verification Procedure:

Design to conform to applicable regulations and verify by appropriate means.

This principle is likely to be particularly important for after market installers and therefore they should consult with the vehicle manufacturer regarding the applicable fields of view.

Examples:

Good: A display mounted within the instrument panel such that it can be easily viewed by the driver but does not interfere with driver's field of view requirements.

Bad: A display mounted on top of the instrument panel such that it obscures a substantial portion of the driver's field of view, as defined by applicable safety regulations.

If the physical position of a component of the system can be modified by the driver and can (as part of its intended range of movement) obstruct the driver's vision, then the driver should be informed through the system instructions about the use as intended by the manufacturer. If no such information is provided to the driver, then the Principle should apply throughout the range of adjustment of the system or its component.

1.3 No part of the physical system should obstruct any vehicle controls or displays required for the driving task.

Rationale:

The purpose of this Principle is to ensure that the driver's ability to use mandatory displays and controls and other displays and controls required for the primary driving task is not compromised by the physical presence of a system (such as a display). This ensures that the driver's ability to be in full control of the vehicle is not adversely affected by installation of the system.

Criterion/Criteria:

A system must be installed to conform to vehicle manufacturers' instructions and recommendations.

Verification Procedure:

Design to conform and validate by appropriate means (e.g., analysis, inspection, demonstration, or test).

Examples:

Good: A route-guidance display integrated into the instrument panel in a high, central position that does not obstruct any other displays or controls.

Bad:

1. An after market route guidance system that obstructs the defroster switches.
2. An additional control on the steering wheel rim that makes the steering wheel more difficult to use during cornering.

1.4 Visual displays that carry information relevant to the driving task and visually-intensive information should be positioned as close as practicable⁴ to the driver's forward line of sight.

Rationale:

For a driver to be in full control of the vehicle and aware of the dynamic roadway there is a broad consensus that, apart from brief glances at mirrors or instrumentation, the driver's gaze should be directed towards the roadway. Visual displays positioned close to the normal line of sight reduce the total eyes-off-the-road time relative to those that are positioned further away. Such positioning also maximizes the possibility for a driver to use peripheral vision to monitor the roadway for major developments while principally looking at the display.

A manufacturer may use either Criterion 1.4A or Criterion 1.4B below to define the allowable downward viewing angle to displayed information. One is for use in two-dimensional Computer Aided Design (CAD) analyses, and one is for use in three-dimensional CAD analyses. Both of these criteria have been derived from research that underlies a JAMA guideline on downward viewing angle. As a result, these criteria are based on a reference point called the Japanese eye point. In order to apply these practices in North America in a way that is consistent with Japanese criteria, it is necessary to establish a corresponding point in terms of North American practice. In this principle, therefore, the term 'eye point' is the SAE equivalent of the JIS (Japanese Industrial Standard) eye point,⁵ which is the SAE J941⁶ 2D eyellipse side view intersection of XX and ZZ locator (datum) lines. This corresponding point is located 8.4 mm up and 22.9 mm rearward of the mid-eye centroid of the SAE eyellipse.

It should be noted that if more than one in-scope display is present in the vehicle that can be viewed by the driver, both displays must meet the criteria prescribed in this principle, or non-compliant displays must be disabled or otherwise rendered non-viewable by the driver while the vehicle is in motion (i.e., traveling at a speed greater than 5 mph).

Criterion 1.4A (for use in two-dimensional analysis):

If head-down, the display shall be mounted in a position where the 2D downward viewing angle is less than or equal to 30 degrees at the geometric center of display.

Since the eye point height from the ground differs greatly between passenger cars and large trucks, the relationship between eye point height and the perceptible distance was calculated with a compensation equation given below in equation (1) in relation to the eye point height from the ground.

⁴ Practicability is introduced to allow a reasonable trade-off between closeness to the driver's normal line of sight and other issues of allocation of devices to a limited instrument panel space.

⁵ JIS Eye Point is defined by JIS D0021 and JIS D1702.

⁶ SAE J941 June 1997 revision.

When the height of the eye point above the ground is 1700 mm or more, the display shall be mounted in the position at which the downward viewing angle shall be less than the value obtained from the formula:⁷

$$\text{Angle (degrees)} = 0.01303 \times (\text{eye point height from the ground (mm)}) + 15.07 \quad (1)$$

Although no lateral viewing angle provision is specified, current research has validated this principle only for display locations up to 40 degrees laterally from the driver. The intent of this principle is to apply to visually intensive displays located in the instrument panel center stack.

Criterion 1.4B (for use in three-dimensional analysis):

If information subject to this principle is displayed at a head-down location, the displayed information must be located at or above the criterion downward viewing angle⁸ at the geometric center of the active display area as determined by the following procedure.⁹ Note that the “active display area” excludes unused display surface and hard switches. Fig. 1¹⁰ shows the three-dimensional reference system that will be used to describe the method.

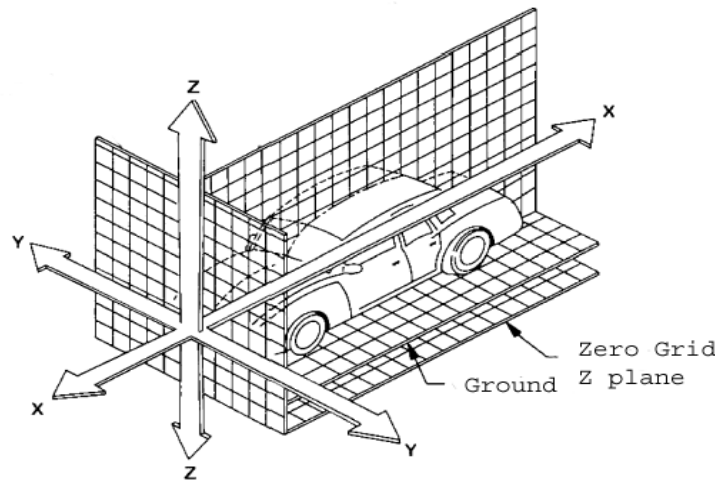

Fig. 1. Three-dimensional reference system (redrawn from SAE J1100).

⁷ The coefficient of the eye height from ground is set at 0.01303 to be consistent with the JAMA published guidelines (JAMA, 2000), although 0.013 is used in Eq. 5 in Yoshitsugu *et al.* (2000). This difference does not materially affect the calculations.

⁸ Although no lateral viewing angle provision is specified here, Yoshitsugu *et al.* (2000) validated this principle only for display locations up to 40 degrees laterally from the driver.

⁹ Alternatively, the display may be mounted in a position where the downward viewing angle is less than or equal to the criterion viewing angle at the geometric center of display.

¹⁰ Adapted from SAE J1100 “Motor Vehicle Dimensions,” July 2002 revision, their Fig. 1.

The maximum allowable 3D downward viewing angle (*3D downangle*) for a particular vehicle is set in a manner consistent with the Yoshitsugu, Ito, and Asoh (2000) data that formed the basis for the 2D downward viewing Criterion 1.4A. In particular, the maximum allowable 3D downward viewing angle is given by the dimensions of the CAD model in Yoshitsugu *et al.* (2000, their Fig. 3), which they used to express the main findings of their study in 3D terms. The maximum 3D downangle is likewise set to be dependent upon the height of the eye point above ground, again as per Yoshitsugu *et al.* (2000, their Eq. 5). *Ground* is here defined as in terms of *curb weight* as per SAE J1100 (Revised Jul 2002), Section 3.2.1,¹¹ and will be referred to as *SAE curb ground* or *curb ground* in the rest of this section. Fig. 2 shows the “Eye Box” that illustrates the symbols and variables used in describing the 3D downangle procedure.

Maximum Allowable 3D Downward Viewing Angle:

The method to derive the appropriate maximum allowable 3D downward viewing angle for a specific vehicle is described below.

- a) *Measure the height Z_{ground} of the J.I.S. eye point from the SAE curb ground for the vehicle.* In North America, this would be the distance from the mid-eye centroid of the SAE eyellipse to the SAE curb ground for that vehicle, plus 8.4 mm to convert to JIS eye coordinates.
- b) *Substitute the greater of Z_{ground} or 1146 into the right side of Eq. 1, and calculate the angle.* The calculated angle is the maximum allowable 2D downward viewing angle for that particular eye height, here termed θ_{2Dmax} . It is measured from the JIS eye point to the display point in side view. That is, the JIS eye point and target point are projected to the same side plane, and then the angle between the two points is the maximum 2D downangle (see θ_{2D} angle E'T'T in Fig. 2). Unlike Principle 1.4A, the maximum 2D downangle limit is variable for vehicles with eye-to-ground heights less than 1700 mm as well as greater than 1700 mm, following Eq. 1 and results from Yoshitsugu *et al.* (2000). θ_{2Dmax} is used here solely as an intermediate step in calculating the maximum allowable 3D downward viewing angle as per step (c). Note: θ_{2Dmax} is a different angle than the criterion 2D angle described in principle 1.4A and is not intended to be used as a substitute for the 2-D angle method in section 1.4A

¹¹ In Section 1.4B, coordinate dimensions are specified as per SAE J1100 Revised JUL2002: “*Unless otherwise specified, all dimensions are measured normal to the three-dimensional reference system (see SAE J182), except ground-related dimensions, which are defined normal to ground. All dimensions are taken with the vehicle at curb weight unless otherwise specified.*” The term *curb weight* is defined in SAE J1100 Revised JUL2002 section 3.2.1: “*CURB LOAD, CURB WEIGHT—The weight of the base vehicle (standard equipment only), with all fluids filled to maximum (fuel, oil, transmission, coolant, etc.).*” SAE curb weight shall define the ground plane for Section 1.4B of this document. Numerous other definitions of ground planes have been used both internally by vehicle OEMs and by U.S. government agencies for various purposes. However, other definitions are subject to interpretation, such as the specification of optional vehicle content. SAE curb weight is currently the only ground plane on which vehicle values are routinely publicly reported by vehicle companies selling in North America. Finally, the tire size tends to be smallest in the base vehicle, leading to a lower eye height and stricter section 1.4B criterion compared to larger tire sizes (see next Section “Maximum Allowable 3D Viewing Angle”). It is to be noted that the zero-grid Z plane (see Fig. 1) must not be used as the ground plane for Section 1.4B, because it is an arbitrary grid not directly related to true ground.

c)

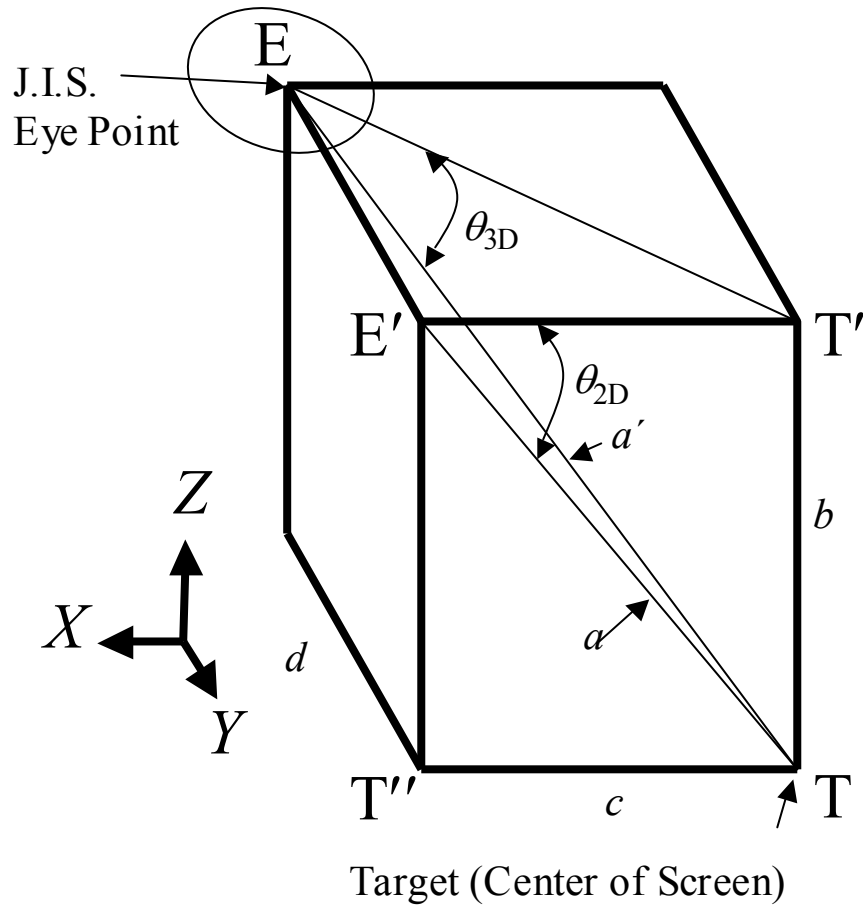

X, Y, Z = vehicle coordinates in front-rear (X), side-side (Y), and up-down (Z) directions

E = J.I.S. Eye Point

E' = Projected J.I.S. Eye Point

T = Target Point on display screen

T', T'' = Projected Target Points

b = downward distance in Z direction (ΔZ) between eye point and target point

c = forward distance in X direction (ΔX) between eye point and target point

d = cross-car distance in Y direction (ΔY) between eye point and target point

a = length of eye-to-target ray in projected (side) view, or the distance $E'T$ from eye to target when both points are projected onto the same side plane = $\sqrt{b^2 + c^2}$

a' = length of 3D ray from eye point E to target point T = $\sqrt{a^2 + d^2}$

θ_{2D} = 2D downward viewing angle $E'T'T = \text{atan}(b/c)$

θ_{3D} = 3D downward viewing angle $ET'T = \text{asin}(b/a')$

Fig. 2. Definition of axes and symbols for box encompassing the eye and the display. The X, Y, Z axes are vehicle coordinates as per Fig. 1. The drawing defines an *eye box* formed by the eye point E (the upper left corner of the eye box), and the target point T on the display (the lower right corner of the eye box). The view is from the right side of the vehicle towards the driver. The plane $E'T'T''$ is the right face of the eye box, often at or near the centerline of the vehicle.

d) Convert this 2D angle solution (θ_{2Dmax}) to a 3D angle (θ_{3Dmax}). The 2D angle is the downangle in terms of the side view, but the 3D angle is the true downangle to the display from the driver-centered point of view, measured from the driver's seated position. That is, the 3D downangle is measured in the rotated vertical plane in which lie both the JIS eyepoint and the display point. (It can loosely be thought of as associated with the downangle formed as if the driver rotated his head and then looks down, to direct the center of gaze to the display point.) θ_{3Dmax} is the maximum allowable 3D downward viewing angle for a given vehicle with a certain eye height above ground, as given by Eq. 2.

$$\theta_{3Dmax} = \arctan[\tan(\theta_{2Dmax} * \pi/180)/\text{sqrt}(1 + d_{00}^2/c_{00}^2)] \quad (2)$$

Note that c_{00} and d_{00} in Eq. 2 are the specific vehicle dimensions from the Yoshitsugu *et al.* (2000) CAD model summarizing their empirical data, and *not* the values for the new test vehicle under investigation. The value of c_{00} is the forward distance from the eye point to the vertical plane ($Y-Z$ plane, see Fig. 1) containing the display point, and d_{00} is the cross-car distance between the eye-point and the vertical plane ($X-Z$ plane, see Fig. 1) at the centerline of the vehicle, for the Yoshitsugu *et al.* (2000) CAD model.¹² Yoshitsugu¹³ gives these values as $c_{00} = 550$ mm, $d_{00} = 370$ mm. Substituting, Eqs. 1 and 2 may be combined and simplified into Eq. 3. This method ensures that the more general equations for the 3D downangle derived here always contain the Yoshitsugu *et al.* (2000) model and empirical data as a special case.

$$\theta_{3Dmax} = 57.2958 \arctan[0.829722 \tan(0.263021 + 0.000227416 \max(1146, Z_{ground}))] \quad (3)$$

Fig. 3 shows that the maximum allowable 3D angle goes from 25.6 degrees at an eye height above ground of 1146 mm to 35.93 degrees at an eye height of 2000 mm.

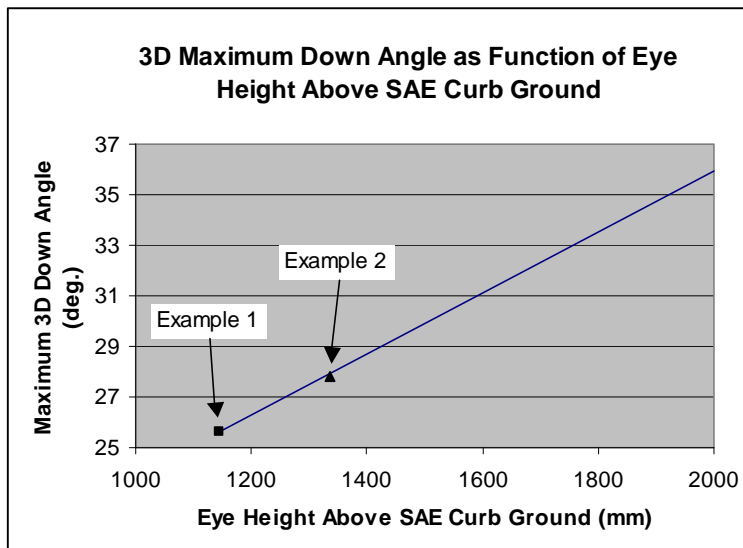

Fig. 3. Maximum 3D downangle as a function of eye height above ground for Principle 1.4B. The points labeled “Example 1” and “Example 2” are discussed in the next two sections.

¹² The centerline of the vehicle and the centerline of the display coincide in the Yoshitsugu *et al.* (2000) model.

¹³ Personal communication.

In short, this method guarantees that the calculations for a new vehicle 3D maximum downangle encompass the empirically based CAD model and equations as given in Yoshitsugu *et al.* (2000). That is, the Yoshitsugu *et al.* (2000) model has now been generalized to allow for a true “3D” downangle, which more closely approximates the actual downangle of the driver’s head and/or eyes when observing the display.

Example 1: Yoshitsugu *et al.* (2000) CAD model car

For the eye height Z_{ground} of 1146 mm used in the Yoshitsugu *et al.* (2000) CAD model, the θ_{2Dmax0} value via Eq. 2 is exactly 30 degrees (the identical 30-degree 2D downangle limit value as per Criterion 1.4A).¹⁴ The maximum permissible 3D downangle θ_{3Dmax0} for Yoshitsugu *et al.* (2000, their Fig. 3) for the eye height of 1146 mm is then 25.6 degrees via Eq. 2 or Eq. 3 (see point labeled “Example 1” in Fig. 3).

Table 1 gives the parameters of the driver-car model that Yoshitsugu *et al.* (2000) matched to their forward event braking data. The 3D downangle limit is 25.6 degrees for the particular car used in their study with the parameters given, when the display location is at the maximum 2D downangle of 30 degrees.

Parameter Description	Parameter	JIS Eye	Units
J.I.S. eye point height from SAE curb ground	Z_0	1146.00	mm
Maximum 2D downward viewing angle for this eye height	θ_{2Dmax0}	30.00	deg
Maximum 3D downward viewing angle for this eye height	θ_{3Dmax0}	25.60	deg
Forward distance from eye centroid to display point (ΔX)	c_0	550.00	mm
Cross-car distance from eye point to display point (ΔY)	d_0	370.00	mm
Height distance from eye point to display point (ΔZ)	b_0	317.54	mm
Length of eye-to-target ray in projected (i.e. side) view	a_0	635.09	mm
Length of eye-to-target ray in true (i.e. 3D) view	a'_0	735.01	mm
Actual 2D downward viewing angle (using curb ground)	θ_{2D0}	30.00	deg
Actual 3D downward viewing angle	θ_{3D0}	25.60	deg

Table 1. The parameters for the Yoshitsugu *et al.* (2000) CAD model that match their empirical driver performance braking data to forward events. The maximum 2D downward viewing angle is 30 degrees, which the actual display just meets. The corresponding maximum 3D downward viewing angle is 25.6 degrees, which the display also just meets, as predicted by Principle 1.4B. degrees, which the actual display just meets. The corresponding maximum 3D downward viewing angle is 25.6 degrees, which the display also just meets, as predicted by Principle 1.4B.

Fig. 4 illustrates a more general 3D solution that includes the Yoshitsugu *et al.* (2000) CAD model as a special case. For illustrative purposes, it is easiest to reference the driver coordinate system to an eye point located at (0,0,0). The 2D downward viewing angle of the display point (marked T in

¹⁴ The θ_{2Dmax0} value can be easily calculated in the Yoshitsugu *et al.* (2000) CAD model because the center point of the display was at the center line of the vehicle – that is, the display was centered on the center stack in the middle of the vehicle, midway in cross-vehicle distance between the driver and the passenger.

Fig. 2) is at the 2D maximum of 30 degrees. The horizontal 2D constraint line in Fig. 4 shows that the 2D angle stays fixed at 30 degrees (317.54 mm below the eye point in side view) as a function of cross-car distance. The curved line in Fig. 4 labeled “1.4B 3D constraint line” gives the permissible maximum permissible downward distances for the 1.4B criterion for that vehicle as a function of cross-car distance. The 3-D downward viewing angle is fixed at 25.6 degrees for that curved line.

The 3D constraint line in Fig. 4 is equivalent to assuming a line is positioned with one end at the eye point, and the other at the instrument panel. The line is then swept from the centerline of the driver (that is, from $d = 0$ mm), to some position to the right of the centerline of the vehicle (say $d = 800$ mm). The intersection of the line with the vertical $Y-Z$ plane in which the display point lies is the 3D constraint line in Fig. 4. The length of the line (or ray) from the eye point to the display point is given by Eq. 4.

$$a' = \text{sqrt}(a_0^2 + d^2) \quad (4)$$

The downward physical limit b_{sweep} is where the swept line intersects the vertical $Y-Z$ plane in which the display point lies. This sweep is a hyperbola, given by Eq. 5.

$$b_{\text{sweep}} = a' \sin(\theta_{3D\text{max}} * \pi/180) \quad (5)$$

This swept line in fact traces out a cone. Let C denote a right circular cone with apex at the eye point, central axis vertical, and central (or apex) angle equal to $(180 - 2 * \theta_{3D\text{max}})$ in degrees. (Note: the central angle of a cone is the angle across the full diameter of the cone, not just its radius.) Then every longitudinal (or rectilinear) element of C 's surface is a line of sight deflecting downward from the horizontal plane by the angle $\theta_{3D\text{max}}$. Moreover, the surface of C is the locus of all such lines of sight. It does not take a great deal of geometric intuition to see the validity of this construction. Clearly, every longitudinal element of a right circular cone's surface makes a fixed angle with the central axis, that angle being one-half the apex angle --- in the case of C , this half-angle is $(90 - \theta_{3D\text{max}})$. If the central axis is vertical, the angle with respect to the horizontal is $\theta_{3D\text{max}}$.

This swept line or cone method is further described and illustrated in the verification method 2 for Principle 1.4B, and Figs. 9-11. Without benefit of analysis, we know that the intersection of C 's surface with a vertical plane must be a hyperbola. (In the study of conic sections, a cone extends to infinity in both directions from the apex, so that a plane parallel to its axis will intersect the cone's surface in two disconnected branches, necessitating that the intersection be hyperbolic. In our case, we are interested only in that half of the cone that lies below the apex, and only in the lower branch of the hyperbola.) The volume inside the cone represents the locations in which the display point should not be placed.

The 2D angle constraint line (assuming SAE curb ground) is the dashed line in Fig. 4, given by the constant height $b = a' \sin(30 * \pi/180)$.

Fig. 4 shows that when the display point is closer to the driver than the intersection of the two constraint lines, the 3D constraint line is higher (i.e., stricter) than the 2D constraint line given by

Section 1.4A (assuming SAE curb ground for both), whereas the opposite is true for display positions to the right of the intersection point. Hence the 3D method in Section 1.4B is neither stricter nor more permissive than the 2D method in Section 1.4A; it depends upon the cross-car distance of the display.

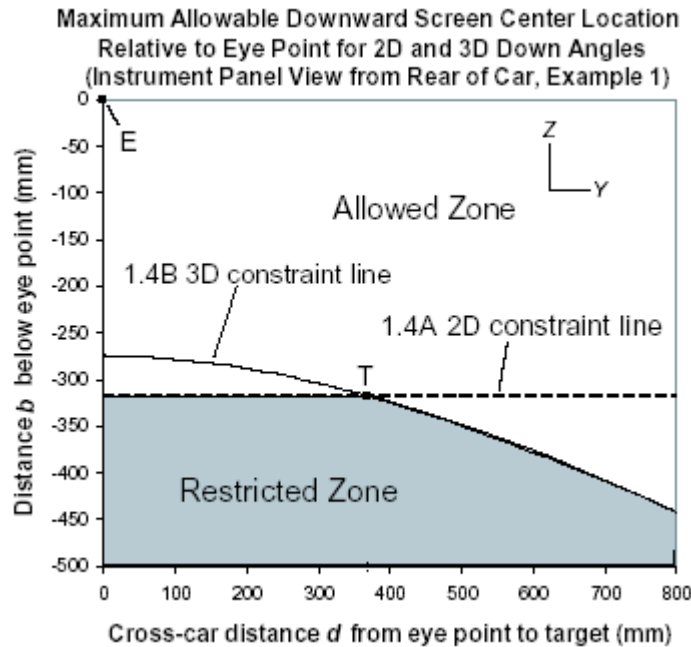

Fig. 4. The graph depicts a view from the rear of the vehicle towards the instrument panel. The graph describes a vertical Y - Z plane containing the display point T in Example 1, which is based on the Yoshitsugu *et al.* (2000) car CAD model. The dashed horizontal line shows the 2D design constraint line above which the display point must be placed, for different cross-car positions d (abscissa). The solid curved line is the 3D design constraint line, above which the display point must be placed to meet criterion 1.4B. As long as the display point T is at or above either the 2D or 3D constraint line, it meets criterion 1.4. In this case, the target point T meets both 1.4A and 1.4B criteria. Point T in this Yoshitsugu *et al.* (2000) CAD model example is at the exact intersection of the 2D and 3D constraint lines.

Obviously, other vehicles will have different sizes than in the Yoshitsugu *et al.* (2000) data and model. Principle 1.4B generalizes the 2D Principle 1.4A to three dimensions, with a true ground line, and ensures that common 3D downangle methods are used for vehicles of different sizes, while ensuring that the Yoshitsugu *et al.* (2000) empirical model is always included as a special case.

Example 2: Solution for a new vehicle design

Assume a new vehicle has eye height $Z_{ground1}$. Let the X , Y , Z distances between the eye point and the display point in the new vehicle be c_1 , d_1 , and b_1 respectively. That is, assume forward distance c_1 , cross-car distance d_1 , and height-offset b_1 between the eye point and the display point. By substituting the actual eye height $Z_{ground1}$ in Eq. 1, the maximum allowable 2D downward viewing angle θ_{2Dmax1} for the new vehicle may be calculated (note that θ_{2Dmax1} is just an intermediate 2-D angle used for calculating the 3-D angle, and is not the same 2-D

angle criterion as in section 1.4A). The maximum 3D downangle θ_{3Dmax1} permitted for this new vehicle design is then derived from Eq. 2 or Eq. 3.

To determine if the new vehicle meets the “3D” downangle criterion from Section 1.4B, calculate the corresponding length of the line from the eye point to the display point in side view, given by $a_1 = \text{sqrt}(b_1^2 + c_1^2)$. Then the distance a_1' from the eye point to the display point along the line of sight to the display is given by $a_1' = \text{sqrt}(a_1^2 + d_1^2)$. The “3D” downangle for this vehicle is then $\text{asin}(b_1/a_1')$, which can be compared with the limit θ_{3Dmax1} .

To illustrate, Table 2 shows a vehicle with its SAE eyellipse centroid coordinates, as well as its JIS eye coordinates and display coordinates measured according to the SAE curb ground plane.

Dimension Description	Dimen.	SAE Eyellipse Centroid	JIS Eye Point	Display Point	Units
Distance behind the front of vehicle	<i>X</i>	3011.31	3034.21	2506.00	mm
Side distance from car centerline	<i>Y</i>	-370.00	-370.00	12.00	mm
Height above SAE curb ground	<i>Z</i>	1327.28	1335.68	969.00	mm

Table 2. Eye centroid and display position for car Example 2.

Fig. 5 shows a side view graph of the point locations in Table 2 along with a CAD model representation of the human mannequin commonly used in automotive applications. Fig. 6 shows the rear view of the same data. Neither view shows the true 3D downangle, which can only be seen in an oblique view.

Table 3 shows the 2D and 3D angle calculations for the Example 2 vehicle, based on the JIS eye point and display point in Table 2, assuming SAE ground coordinates. The display point T is at a 3D downangle value of 29.36 degrees and must be moved up on the instrument panel such that a vertical height increase of at least 1.52 degrees (22.46 mm) occurs, in order to meet the 3D downangle limit of 27.64 degrees. Note that the dashboard is often curved and tilted rather than a vertical plane, so the offset height increase required to meet the criterion should only be viewed as approximation to the actual distance that the display needs to be moved up on the dashboard itself. The final position of the display on the dashboard should be again validated against the criterion after the display is moved upwards in the CAD model.

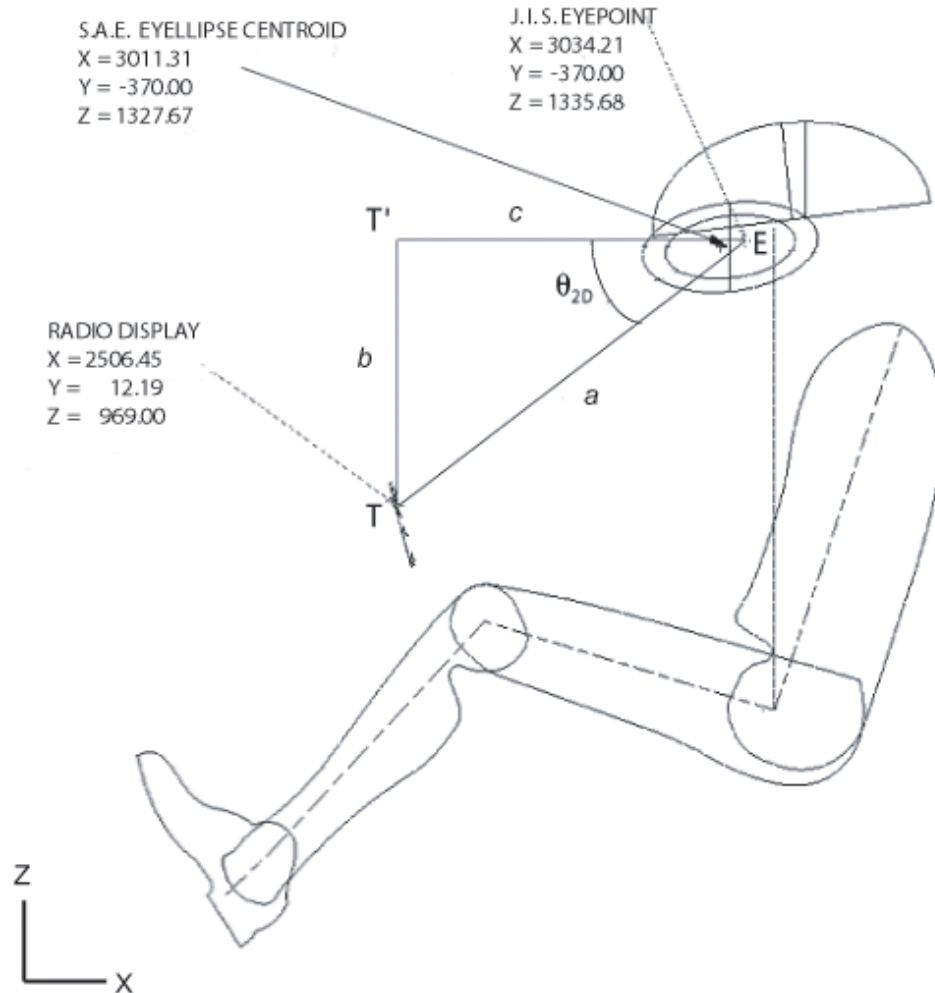

Fig. 5 (top). Example 2, Side view. J.I.S. Eye Point E and display point T, projected into the side view X-Z plane. θ_{2D} is the two-dimensional downward viewing angle assuming the SAE curb ground plane.

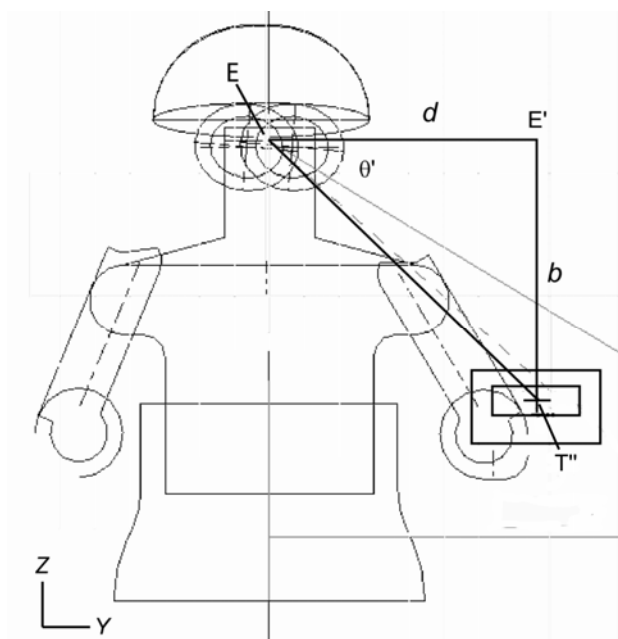

Fig. 6 (left). Rear view. J.I.S. eye point E, projected eye point E' and display point T'' for car example 2, projected into the Y-Z plane. The angle θ' formed from triangle EE'T'' as shown is $\text{atan}(b/d) = 43.84$ degrees. Only the view in the oblique plane formed by ET'T (see for example Fig. 2) will directly show the correct 3D downangle of 29.36 deg.

Parameter Description	Parameter	JIS	
		Eye	Units
J.I.S. eye point height from SAE curb ground	Z_1	1335.77	mm
Maximum 2D downward viewing angle for this eye height	θ_{2Dmax1}	32.48	deg
Maximum 3D downward viewing angle for this eye height	θ_{3Dmax1}	27.84	deg
Forward distance from eye point to display point (ΔX)	c_1	528.21	mm
Cross-car distance from eye point to display point (ΔY)	d_1	-382.00	mm
Height distance from eye point to display point (ΔZ)	b_1	366.77	mm
Length of eye-to-target ray in projected (i.e. side) view	a_1	643.06	mm
Length of eye-to-target ray in true (i.e. 3D) view	a'_1	747.96	mm
Actual 2D downward viewing angle (for SAE curb ground)	θ_{2D1}	34.77	deg
Actual 3D downward viewing angle	θ_{3D1}	29.36	deg

Table 3. 2D and 3D angle calculations for car in Example 2 based on J.I.S eye point.

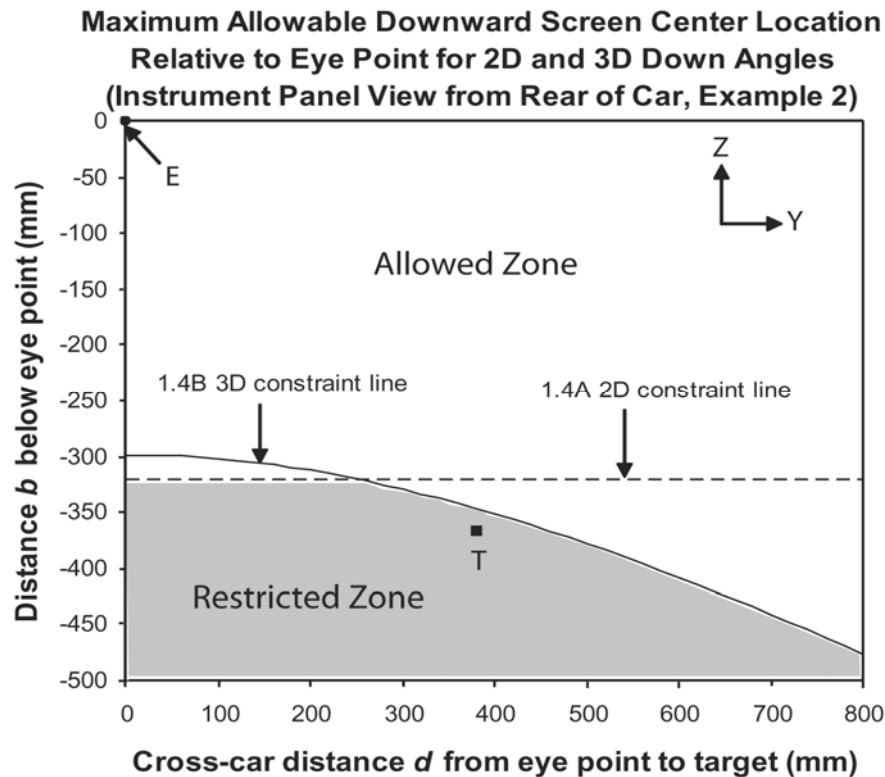

Figure 7. Instrument panel zones for Example 2. The horizontal dashed line is the 30-degree downangle 2D constraint line assuming SAE curb ground for this example. The curved solid line is the 3D constraint line based on a constant downangle from the driver's viewpoint. The J.I.S. eye point is E and the actual display point location is T. The display needs to be raised vertically at least 1.52 degrees (22.46 mm) to meet the 3D downangle criterion of 27.84 degrees for this vehicle.

It would again be useful for design and vehicle architecture purposes to evaluate the downward viewing limit for the vehicle not just for one particular display location, but for an extended constraint line on the instrument panel above which the display point should be placed. This constraint line allows determination of how high the display must go for all side-to-side positions along the instrument panel.¹⁵ By treating the cross-vehicle distance d as a variable, a 3D downangle constraint line b_{sweep} on the instrument panel as a function of d is then given by substituting a_1 into Eq. 4 for a_0 , and θ_{3Dmax1} for θ_{3Dmax0} in Eq. 5. The intersection of a plane and a swept line at a constant downangle from the horizontal, traces a hyperbola.

Fig. 7 illustrates this constraint line method for the car parameters in Example 2. It can be easily seen that the target point T in Fig. 7 is in the restricted zone for both the 1.4A and 1.4B downangle criteria. It is easy to see from Fig. 7 that the display must be raised about 22 mm vertically to meet the 3D criterion of Principle 1.4B.

Justification:

A driver will be better able to monitor the roadway and the driving environment if the display location is kept as close as practicable to the driver's forward view. A display that is located too low in the vehicle may divert the driver's attention from the roadway and may cause a dangerous situation. Several recent studies on driver inattention or distraction have shown that rear-end type crashes are a predominant scenario (Hendricks, *et al.*, 2001; Stutts, *et al.*, 2001; Wang, *et al.*, 1996).

This Principle is based on the JAMA Guidelines concerning the monitor location of image display devices, and test results on which these Guidelines are based. These provisions were adopted when the Guidelines were revised in February 2000.

Yoshitsugu *et al.* (2000) determined the lower limit of a display's downward viewing angle at which drivers focused on the display are still able to perceive they are closing on a preceding vehicle within the distance needed to avoid a rear-end collision. It should be noted that, to date, this study appears to be the only one published which has addressed downward viewing angle in terms of the driver's ability to perceive a lead vehicle at the time that a glance to an in-vehicle display is occurring. As such, it has formed the basis for criteria 1.4A and 1.4B above. However, it would be very desirable to have a more substantial body of research on which to base these criteria and it is an area that deserves further research in the future so that these criteria and verification procedures can be refined. In the future, as additional research is conducted and becomes available, it can be applied to improve and solidify the criteria under Principle 1.4.

¹⁵ The general constraint solution for a curved or sloping instrument panel is more complicated than for the planar assumption, but can be established via a direct CAD model if needed.

Pertinent to the current criteria, however, is the method used in the JAMA study to define an allowable downward viewing angle. This method included:

- Visual target: The visual target for the driver of the test vehicle was a preceding vehicle that was stopped on road with its brake lights illuminated.
- Visual task: Test subjects were instructed to watch for a preceding vehicle by means of peripheral vision while looking intently at single-digit numbers (7 mm in height).
- Evaluation index: The distance at which test subjects became aware of presence of the preceding vehicle by means of peripheral vision measured and defined as perceptible distance was the evaluation index for this task.

Calculation of Lower Limit of Display:

Based on the experimental results, the relationship between (1) the distance at which drivers can perceive they are closing on a preceding vehicle while gazing at the monitor and (2) the downward viewing angle of the monitor, can be approximated with Eq. 3 (Yoshitsugu *et al.*, 2000) for a passenger car (eye point height from the ground of 1146 mm).

$$y = -1.151 x + 85.250 \text{ (average value)} \quad (3)$$

This relationship is shown in Fig. 8.

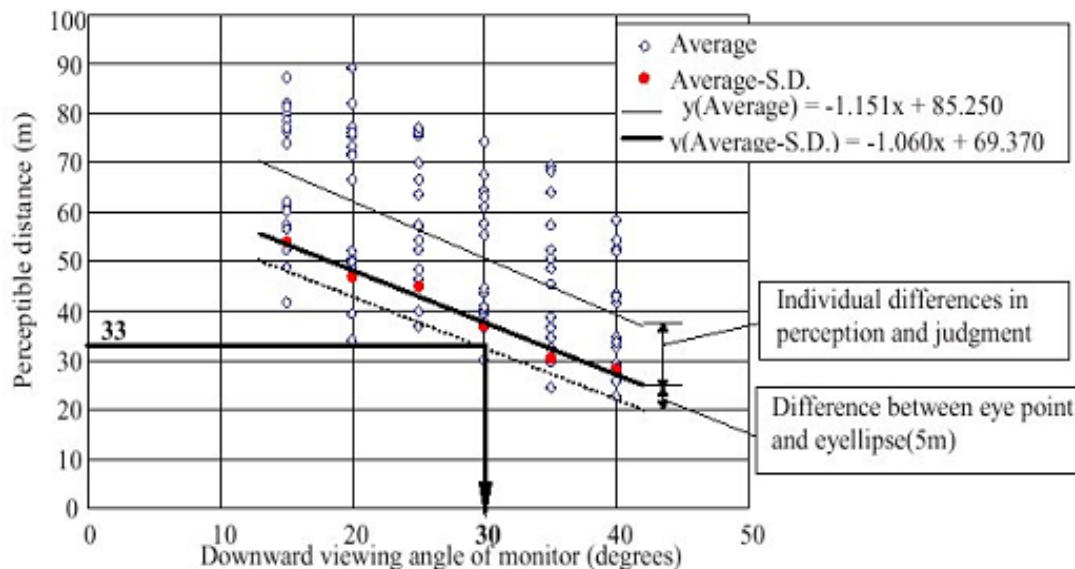

Fig. 8. Relationship between downward viewing angle of display and perceptible distance (from Yoshitsugu *et al.*, 2000).

A rear-end collision may be avoided if the following vehicle begins to brake by the time it reaches a point where the preceding vehicle started to brake. Consequently, the required headway must include braking response time of the driver of the following vehicle.

A conservative estimate of approximately 2 second headway may be considered desirable, as it includes delayed reactions and variation among drivers when braking suddenly to avoid an unexpected vehicle ahead in city driving (Olsen, et. al, 1986). From this headway time, at 60 km/h drivers should be able to detect a preceding vehicle at a distance of 33 meters.

In order to account for individual differences in perception, judgment and vision, it was decided to subtract the average standard deviation (S.D.) of the perceptible distance from the average value. From the data in Figure 6, the relationship between the average S.D. of the distance for perceiving a preceding vehicle and the downward viewing angle of the monitor can be approximated with the following equation (see Figure 6):

$$y = -1.060 x + 69.370 \quad (\text{average} - \text{S.D.}) \quad (4)$$

The difference in the monitor's downward viewing angle in terms of the eye point and the normal eyellipse is approximately 5 degrees, which corresponds to a difference of approximately 5 meters in the distance for perceiving a preceding vehicle (see Figure 2). In order to account for difference in eye point positions, a margin of 5 meters should be provided for the perceptible distance.

From Figure 8 above, at a perceptible distance of 33 meters in city driving, the intersection of the difference between eye point and ellipse data occurs at approximately a 30° downward viewing angle. Taking the above considerations into account, the lower limit of the downward viewing angle of the screen in a passenger car was found to be approximately 30°. This formed the basis for Criterion 1.4A.

The JAMA study also examined perceptible distance to a lead vehicle at various eye height locations (1146 mm, 1393 mm, 1737 mm, and 2388 mm). The results revealed that as drivers' eye height above ground increases, the further they could see down the road.

Essentially, the line of sight to the lead vehicle at elevated eye heights declines slightly from horizontal. This means that a lead vehicle can be detected with display placements at larger downward viewing angles. The authors provided the regression equation specified under Criterion 1B above, as the description of allowable downward viewing angle as a function of eye height. In addition to varying eye height above ground, the JAMA study also examined display locations at various horizontal angles from centerline of driver (in seated position). These results suggest that an angle measured in three dimensions (from driver seated position) is appropriate as lateral displacement of the display increases (within the range studied). Together, the results from both of these

additional research manipulations provided the basis for Criterion 1.4A (in which downward viewing angle is determined as a function of eye point height) and

Verification Procedure 1.4B (with is measured in three dimensions from the driver seated position to the display location).

Criterion 1.4B accounts for the actual downward viewing angle of the driver's vision system when viewing the display. Drivers typically move their head and/or their eyes to a display to bring the fovea or area of highest acuity vision onto the display. The ability of the driver to detect and respond to vehicles or objects on the road ahead when glancing downward is determined by the limits of the human peripheral visual system, more so by the up-down visual dimension rather than the left-right one, as shown in the Asoh et al. (2002) and Yoshitsugu et al. (2000) data, and is well known from human visual periphery studies (see Forbes, 1970). These limits are more closely associated with the actual downward angle in the vertical dimension of the driver's eyes, not the 2D side angle in vehicle coordinates. Therefore, the 3D angle as shown is a better approximation to the driver's actual downward visual angle than the 2D angle measured in the side view, from a human vision standpoint. On this basis, the 2D downangle method in 1.4A is overly strict for cross-car distances greater than the intersection point of the two curves, and overly lenient for cross-car distances smaller than that intersection point (see Fig. 4). The 2D downangle method leads to a constant horizontal constraint line on the instrument panel (see Fig. 4). At greater cross-car distances, this fixed distance down leads to smaller and smaller true visual angles the further the displacement is away from the driver, just due to basic geometry. Likewise, the 2D method may be overly lenient if the cross-car location of the display were to be moved closer and closer to the driver (for example, at or near the instrument cluster). Nonetheless, the 2D method is simple to understand and implement, can be based on grid coordinates without the need for a ground plane definition, and it encourages higher and more optimal display placement at a typical display location in the center stack.

Verification Procedures:

One of the following verification procedures should be used to examine a design relative to the criterion downward viewing angle. The first is appropriate for use with Criterion 1.4A (and represents an angular measurement done in two dimensions at the centerline of the display). It duplicates what is in the JAMA Guidelines. The second procedure is appropriate for use with Criterion 1.4B (and represents an angular measurement done in three dimensions from eye point height at the driver's seated position). It is also appropriate when the height and width of a vehicle might differ from those for which the simpler 2D criterion and measurement were developed.

Both procedures below are to be applied within a computer-aided design or modeling tool (or some equivalent measurement method). Both are also intended to be applied when the seat is in its design nominal position, and the display is located at its design-intent position. This recognizes that some variations around these design nominal positions

may occur at the time of vehicle build or assembly, but need not be individually measured.

Verification Procedure for 1.4A (for use with two-dimensional criterion angles):

If head-down, the display shall be mounted in a position where the downward viewing angle is less than 30 degrees. The downward viewing angle should be set between two lines that project on the vehicle's *Y* plane. The first line projected on the *Y* plane should be drawn from the Japanese eye point – or, in North America, from the corresponding point 8.4 mm up and 22.9 mm rearward of the mid-eye centroid of the SAE eyellipse -- parallel to the *X*-axis. The second line should be drawn from the center of the display monitor to the same eye point (8.4 mm up and 22.9 mm rearward of the mid-eye centroid of the SAE eyellipse (or corresponding point in the Japanese practice). It should be noted that the “center of the display monitor” corresponded to the bottom of the display information in the empirical study upon which this criterion is based.

Verification Procedure 1.4B (for use with three-dimensional criterion angles):

Three alternate methods are given for Section 1.4B, all of which produce an equivalent answer. In all three methods for 1.4B, the world coordinate system (WCS) must be first translated and rotated to align with the SAE curb ground plane, not the original grid coordinate system (see Fig. 1).

Method 1 – CAD Measurement

1. Ensure that both the driver's seat and the display to be analyzed are placed at their respective nominal design positions in the three-dimensional CAD representation (or equivalent).
2. Locate the driver eyellipse according to SAE J941-Rev. June 1997 eyellipse.
3. Determine the location of the centroid of the combined eyellipse (mid-eye centroid), and then find the point corresponding to the Japanese eye point, 8.4 mm up and 22.9 mm back for the SAE eyellipse.
4. Determine the location of the display point, defined as in the first paragraph of Section 1.4B.
5. Determine the 3D downward viewing angle. This can be done by going through steps a, b, and c, below or by using some simple CAD methods noted after step c.
 - a. Construct a line representing the driver's line-of-sight to the display point. This can be done by drawing a line between the eye point (located in step 3, above) and the display point (located in step 4, above). This represents the line-of-sight to the displayed information. (See line ET in Fig. 1).

- b. Construct a line in the horizontal plane of the driver's eyepoint, to a point in that plane directly above the display point (line ET' in Fig. 1). The angle that lies between these two lines (the line of sight to a point in the horizontal viewing plane directly above the display point and the line of sight to the display point) represents the actual downward viewing angle to the display point.
- c. Measure (or calculate) the size of the 3D downward viewing angle using the formula $\theta_{3D} = \text{asin}(b/a')$ (see Fig. 1), where:

a' = Distance from eye point to display point along the line of sight ET to the display.

b = Vertical distance from the eye point down to the horizontal plane encompassing the display point (line T'T in Fig. 1).

If this angle is equal to or less than the maximum allowable downward viewing angle computed for Criteria 1.4B, then the display location meets the criterion.

Method 2 – Swept Line Method

Another way to implement this verification method in a Computer Aided Design (CAD) system is to create a swept line. Construct a single line that has a fixed angle down from the horizontal plane containing the eyepoint – that is, a fixed angle down from the driver's forward line of sight to the roadway. The down angle to the forward line of sight should be set at a value of θ_{3Dmax} -- the maximum allowable 3D downward viewing angle (as determined from Criteria 1.4B). Once anchored and positioned this way, the line can be swept laterally, such that it makes a constant downangle with the horizontal plane containing the eyepoint. This swept line will trace an intersection path on the dashboard representing the lower limit for the display point. This trace is the 3-D constraint line. If the displayed information lies above the intersection of the display and this constraint line, it is considered to meet the 1.4B downward viewing angle requirement.

The swept line also creates a cone.¹⁶ The cone that is generated by the swept line is illustrated in Figs. 9-11. Fig. 9 is a perspective view, Fig. 10 is a rear view, and Fig. 11 is a side view. The apex of the cone is at the eye point. If the criterion display point were inside the boundary of the cone shown, the component placement would not meet criterion 1.4B. If it were outside the boundary of the cone, it would meet criterion 1.4B.¹⁷ The intersection of the cone with the vertical Y-Z plane containing the display point traces a hyperbola, which is the line shown in Fig. 4, labeled “1.4B 3-D constraint line.” The intersection of the cone with the vertical Y-Z plane containing the display point traces a hyperbola, which is the line shown in Fig. 4, labeled “1.4B 3-D constraint line.”

¹⁶ Note: This cone should not be confused with the “cone of vision” or the effective or inductive field of vision as referred to by Yoshitsugu et al. (2000, their Fig. 3).

¹⁷ Although no lateral viewing angle provision is specified, current research has validated this principle only for display locations up to 40 degrees laterally from the driver.

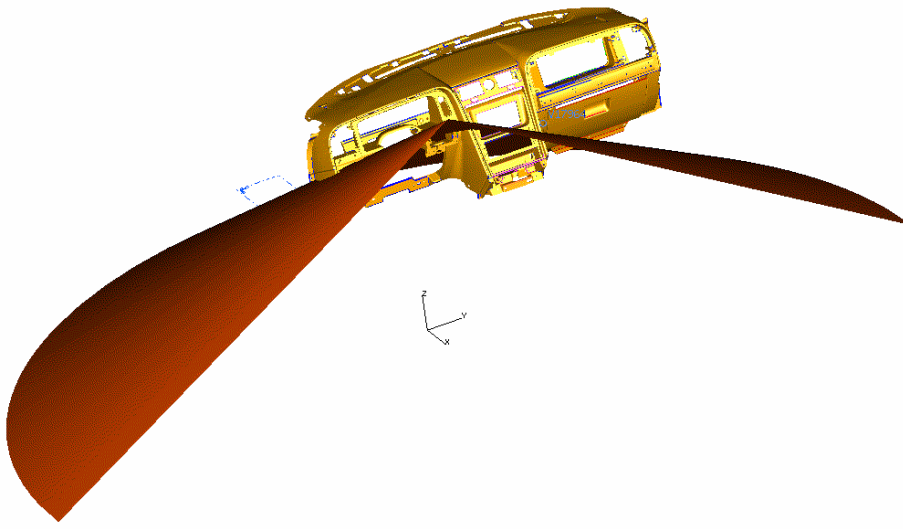

Fig. 9. Perspective view of cone as swept by a line drawn from the eyepoint at a fixed downangle from the horizontal plane containing the eyepoint, with coordinate system aligned with SAE curb ground. The eyepoint is at the apex of the cone. The smaller shaded object is the instrument panel. The rear portion of the cone cut away so the interior can be seen. If the display point is outside the boundary of the cone, it meets criterion 1.4B.

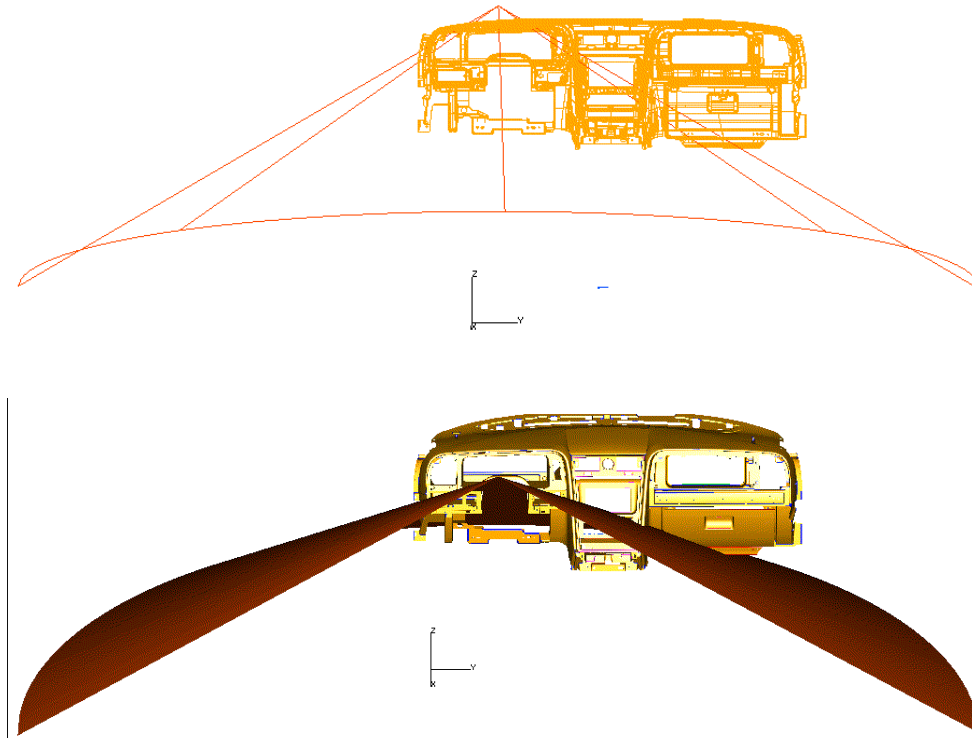

Fig 10. Rear view of same cone and instrument panel as in Fig. 9. The top picture is a wire frame view, and the bottom picture is a solid view, with the rear portion of the cone cut away so the interior can be seen.

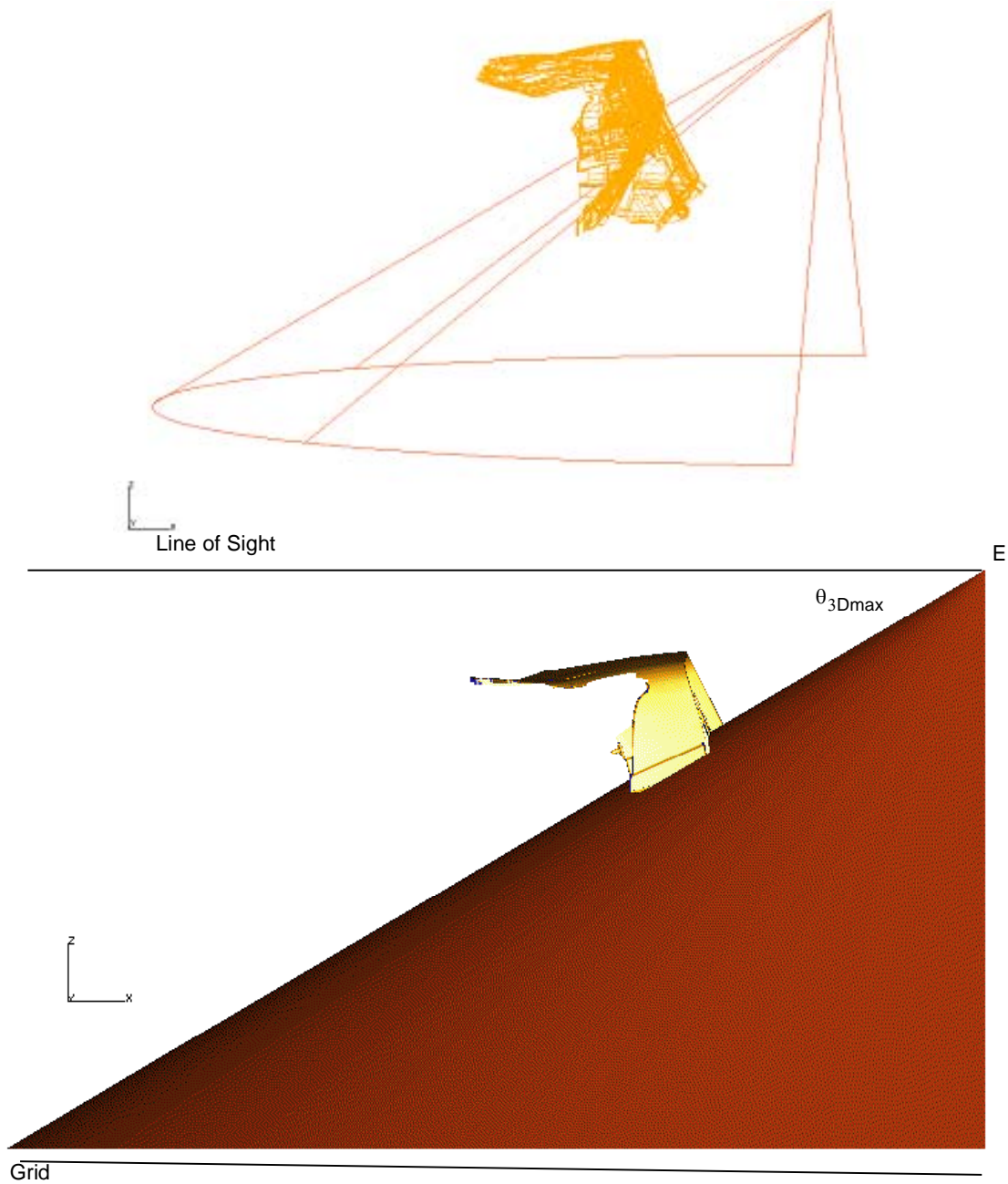

Fig. 11. Side view of same cone and instrument panel as in Fig. 9 and 10 (coordinate system aligned with SAE curb ground). The top view is wire frame, and the bottom view is solid. Consider a horizontal line extending to the left from the eye point E at the upper right – that would be the line of sight. The angle between the line of sight and a lower line is fixed at θ_{3Dmax} . This line then sweeps out the cone shown. Note that the grid coordinate line (bottom of image) is at a slight tilt with respect to the SAE curb ground coordinates in this case. If the vehicle had been (incorrectly) measured on the grid coordinate system, the rear of the vehicle would have been lowered relative to the front of the vehicle, incorrectly decreasing the measured 3D downangle.

Method 3 – Two-Point Math-Based Method

A final way to implement method 1.4B is to ask a CAD operator to determine the X, Y, Z values of two points: the mid-eye eyellipse centroid, and the display point. Note: the X and Z values need to be determined with respect to the SAE curb ground plane, not the grid coordinate system of the vehicle (see Fig. 1). Then the formulas given below can be easily placed for example in an Excel spreadsheet to calculate the maximum allowable 3D angle, and the actual 3D angle.

Let $X_{display}, Y_{display}, Z_{display}$ be the coordinates of the display. Let $X_{eyeSAE}, Y_{eyeSAE},$ and Z_{eyeSAE} be the SAE eye coordinates. Then calculate the JIS eyepoint as:

$$\begin{aligned}X_{eyeJIS} &= X_{eyeSAE} + 22.9 \text{ (rearward)} \\Y_{eyeJIS} &= Y_{eyeSAE} \\Z_{eyeJIS} &= Z_{eyeSAE} + 8.4 \text{ (upward)}\end{aligned}$$

Then calculate:

Forward distance from eyepoint to display point (ΔX or c) = $X_{eyeJIS} - X_{display}$
Cross-car distance from eyepoint to display point (ΔY or d) = $Y_{eyeJIS} - Y_{display}$
Actual height distance from eyepoint to display (ΔZ or b) = $Z_{eyeJIS} - Z_{display}$
Length of eye-to-target ray in true (i.e. 3D) view (a') = $\text{SQRT}(b^2 + c^2 + d^2)$

Finally calculate:

Maximum 2D downangle for this eye height = $\theta_{2Dmax} = 0.01303 * Z_{eyeJIS} + 15.07$

Maximum 3D downangle for eye height = $57.29 * \text{ATAN}(\text{TAN}(\theta_{2Dmax} * 0.017) / \text{SQRT}(1 + d_{00}^2 / c_{00}^2))$

Actual 3D downangle = $\text{DEGREES}(\text{ASIN}(b/a'))$

Note that c_{00} must be fixed at 550 mm, and d_{00} at 370 mm, based on the JAMA CAD model of the experimental results (see section *Maximum Allowable 3D Downward Viewing Angle*).

A spreadsheet tool that assists the user in making these calculations can be found on the Alliance website www.autoalliance.org.

Examples:

Good: Visual display positioned high on the instrument panel towards the driver's side of the central console, but not being obstructed by the steering wheel or obstructing the forward vision.

Bad: Display positioned too low in the console area towards the front passenger's side or within a glove compartment.

References:

Asoh, T., Kimura, K., and Ito, T. (2000) "JAMA's study on the location of in-vehicle displays," SAE Paper 2001-01-C010.

Forbes, L. M. (1970) "Geometric Vision Requirements in the Driving Task," SAE #700395, Automobile Safety, 1970 - Conference Compendium. International Automobile Safety Conference (Detroit and Brussels), Society of Automotive Engineers, series P-30, Conference held May 13-15, 1970, Detroit, MI; June 8-11, 1970, Brussels, Belgium.

Hendricks, D.L., Fell, J.C., & Freedman, M. (2001) "The Relative Frequency of Unsafe Driving Acts in Serious Traffic Crashes," Prepared for U.S. Department of Transportation, National Highway Traffic Safety Administration, Traffic Safety Programs, Office of Research and Traffic Records, Under Contract No. DTNH22-94-C-05020.

Japanese Industrial Standards (2000): JIS D 0021. Eye range of drivers for automobiles. <http://www.webstore.jsa.or.jp/webstore/Top/indexEn.jsp> (In Japanese). See also ISO 4513:2003 "Road vehicles - Visibility - Method for establishment of eyellipses for drivers eye location" Available from <http://webstore.ansi.org/>.

Japanese Industrial Standards (1996): JIS D 1702:1996. Road vehicles -- Test method for the direct driver's field of view. <http://www.webstore.jsa.or.jp/webstore/Top/indexEn.jsp>. (In English).

JAMA (Japan Automobile Manufactures Association) "Guideline for In-vehicle Display Systems," Version 2.1, February 22, 2000. See [http://www.umich.edu/~driving/guidelines/JAMA_Guidelines_\(Draft\).pdf](http://www.umich.edu/~driving/guidelines/JAMA_Guidelines_(Draft).pdf)

Morita, K., Sekine, M. Mashiko, J. and Okada, T. "Safety of in-vehicle displays of automobiles – effect of mounting position differences," Vision in Vehicles 10, North Holland, Elsevier Science, 2003.

Olson, P.L., *et al.* (1986) "Perception-response time to unexpected roadway hazards," Human Factors: 28(1), pp. 91-96.

SAE J941, Society of Automotive Engineers Surface Vehicle Recommended Practice, "(R) MOTOR VEHICLE DRIVERS' EYE LOCATIONS" Rev. June 1997.

SAE J941, Society of Automotive Engineers Surface Vehicle Recommended Practice, "(R) MOTOR VEHICLE DRIVERS' EYE LOCATIONS" Rev. Sept. 2002.

SAE J1100 Surface Vehicle Recommended Practice, "(R) Motor Vehicle Dimensions" Rev. Jul 2002.

Stutts, J.C., Reinfurt, D.W., Staplin, L., & Rodgman, E.A. (2001) "The Role of Driver Distraction in Traffic Crashes, Phase I Final Project Report," University of North Carolina Highway Safety Research Center Chapel Hill, NC. Prepared for AAA Foundation for Traffic Safety 1440 New York Avenue, NW, Suite 201, Washington, DC.

Wang, J., Knipling, R.R., & Goodman, M.J. (1996) "The Role of Driver Inattention in Crashes; New Statistics from the 1995 Crashworthiness Data System."

Yoshitsugu, N., Ito, T., & Asoh, T. (2000) "JAMA's Safety Guideline on In-vehicle Display Systems (The study of monitor location of in-vehicle Displays)."

1.5 Visual displays should be designed and installed to reduce or minimize glare and reflections.

Rationale:

Direct glare and reflections are likely to make it more difficult to extract information from the display and also may cause distraction from the driving task or other tasks performed while driving. This is likely to lead to increased driver frustration and may evoke behavioral adaptations such as squinting, closing of the eyes for brief periods, and exaggerated head movements to obtain a more comfortable view. Some of these effects may reduce driver comfort and therefore may compromise road safety to some extent. Furthermore, drivers may encounter difficulty with the basic tasks of nighttime driving when bright in-vehicle displays are present. However reflections caused by an open sunroof or convertible top may not always be avoidable.

Areas that should be considered include:

- provision of a (manual or automatic) display brightness control;
- choice of display technology;
- choice of display surface texture and finish;
- choice of color and gloss of surfaces being reflected in the display surface;
- choice of image polarity;
- orientation of the display and adjustability; and
- use of a recess or cowl.

Criterion/Criteria:

Manufacturers to design to conform to applicable industry standards.

Verification Procedure:

Verification should be done by appropriate means (e.g., analysis, inspection, demonstration, or test). See, for example, SAE J-1757 (JUL2002) "Standard Metrology

for Vehicular Displays” and ISO 15008“Road Vehicles – ergonomic aspects of in-vehicle visual presentation for transport information and control systems”.

Examples:

Good: A display that incorporates a screen with an automatic brightness control recessed within the instrument panel in a high, central position which does not produce secondary images on the vehicle’s glass and which has a display front surface that can be easily read under all normal lighting conditions.

Bad: A display whose design and installation does not sufficiently take account of potential glare and reflection problems; an example is a display which is so bright at night that it is significant in the driver’s peripheral vision when looking at the forward road-scene or whose information is difficult to read in sunlight because the contrast is so low.

Section 2.0 Information Presentation Principles

The principles and criteria in this section address information presented by information systems on individual screens as well as sounds delivered by information systems. The Section 2 principles seek to ensure that information presented on individual screens meet accepted practices relative to legibility and understandability, timeliness of information, accuracy, and controllability, and minimize undesirable effects of inappropriately presented information. (Principles dealing with the dynamic use of information across several screens during a user’s interaction with a system to reach a goal are to be found in Section 3.0, rather than in this section.)

Section 2.0 Information Presentation Principles

2.1 Systems with visual displays should be designed such that the driver can complete the desired task with sequential glances that are brief enough not to adversely affect driving.

Rationale:

Visual processing by the driver to take account of the traffic environment forms the basis for accomplishing vehicle control and maneuvering tasks. Too much visual capacity therefore should not be absorbed by secondary tasks.

A task is defined as a sequence of control operations (i.e., a specific method) leading to a goal at which the driver will normally persist until the goal is reached. An example is obtaining guidance by entering a street address using the scrolling list method until route guidance is initiated.

A goal is defined as a system state sought by a driver. Examples include: obtaining guidance to a particular destination; greater magnification of a map display; determining the location of a point of interest; and canceling route guidance.

Criterion/criteria:

It should be noted that the proposed measures and methods to evaluate directly the effect of a communication or information system on driving performance currently are being investigated by automotive manufacturers and other research institutes. These measures and methods, including static variations, will be investigated and brought forward when empirical work is completed. The proposed values and methods therefore are subject to revision or replacement based on new information.

Alternative A. A visual or visual-manual task intended for use by a driver while the vehicle is in motion should be designed to the following criteria:

- A1. single glance durations generally should not exceed 2 seconds; and
- A2. task completion should require no more than 20 seconds of total glance time to task display(s) and controls.

Alternative B. Alternatively, the impact of a device-related visual or a visual-manual task on driving safety can be assessed directly by measuring concurrent driving performance under dynamic conditions and relating it to driving performance under specified reference conditions. The influence of such a secondary task on driving performance shall not be greater than that of a scientifically-accepted reference task in terms of:

- B1. Lateral position control: Number of lane exceedences observed during secondary task execution should not be higher than the number of lane exceedences observed while performing one or more reference tasks (e.g., manual radio tuning) under standard test conditions (e.g., same drivers, driving scenario) replicating routine driving tasks; and
- B2. Following headway: Car following headway variability observed during secondary task execution should not be worse than car following headway observed while performing one or more reference tasks under standard test conditions (e.g., same drivers, same driving scenario) replicating routine driving tasks. This measure is influenced by speed changes of preceding traffic or lane changes of other vehicles.

The reference task of manual-visual interaction should have a comparable number of required, sequential interactions in order to control the influences of manual interaction on measuring visual workload. In the future a table of reference tasks will be developed which classifies tasks according to following criteria:

- display position;
- position of controls;
- number of necessary interactions/steps;
- range of adjustable values: numbers (1-10, analog scale (analog radio), letters);
- type of controls: button; knob; toggle switch
- it should be noted that this list of criteria may be expanded and possibly include tasks that are not device related.

In the interim, reference tasks/device are specified for the purpose of verifying conformity with Alternative B of this principle (see Verification Procedure for Alternative B, below, for details).

Justification for Alternative A:

The criteria for alternative A are defined by means of a “reference task” approach to acceptability. In this approach, reference tasks that reflect typical in-vehicle device interactions or current practice are used as a benchmark. In particular, the 85th percentile of driving performance effects associated with manually tuning a radio is chosen as a first key criterion. This is because manual radio tuning has a long history in the research literature and its impacts on driver eye glance behavior, vehicle control, and object-and-event detection are reasonably well understood. More specifically, radio tuning:

- A) is a distraction source that exists in the crash record (see Stutts, et al, 2001; Wang, Knipling, and Goodman, 1999; Wierwille and Tijerina, 1998) and so has established safety-relevance (see Table 1);
- B) is a typical in-vehicle device interaction; and
- C) represents the high end of conventional in-vehicle systems in terms of technological complexity as well as in terms of impacts on driver performance;
- D) it represents a plausible benchmark of driver distraction potential beyond which new systems, functions, and features should not go;
- E) the radio is a device that is most likely to be supplanted or augmented by new technology in terms of functions and services. News, weather, traffic advisories, entertainment (music, stories), and advertisements currently broadcast in audio to the general public via the radio will be tailored to the individual driver’s needs and interests by emerging technology.
- F) the 85th percentile response characteristics or capability represent a common design standard in traffic engineering.

Criterion A1: The value of 2.0 seconds as a generally acceptable maximum single glance duration (not mean glance duration) was derived from the distribution of single glance durations reported by Rockwell (1988). Figure 1 is a histogram based on 1250 glances obtained from instrumented vehicle studies conducted on public roads over a 10-year period. From the histogram in Figure 1, it can be seen that approximately 180 glances are represented in the histogram beyond 1.9 seconds in duration. This amounts to roughly the 85th percentile since $(1250-180)/1250 \approx 0.85$. This value of 1.9 seconds is rounded to 2.0 seconds to provide an engineering criterion in whole numbers.

It should be noted that analysis by Green (1999) has shown that, in general, eye glance durations are not good predictors of a safety-relevant aspect of driving like lane exceedences. This is thought to be due to the self-limiting nature of eye glances away from the road scene. Drivers are only willing to look away for a brief time. Nonetheless, it is possible that new in-vehicle functions and features might require long glance durations. Thus, this criterion is included for completeness, but is not sufficient in itself.

Tijerina (2000) reports test-track data in which a voice-based destination entry task that took an average of 75 seconds to complete was associated with no (zero) lane exceedences (see Figure 2). Visual-manual tasks all had some lane keeping disruptions, although those with longer trial times (i.e., task completion times) and a low display position were associated on average with more lane exceedences. On the other hand, one of the visual-manually controlled systems (Delco) did not cause significantly more lane exceedences than the reference task of manual radio tuning. It should be noted that the display of this system was mounted significantly closer to the driver's normal line-of-sight, while the radio was an after market unit mounted even lower on the center stack of the vehicle. This seems to indicate the need for further research on the influence of display position. Display location also is addressed separately in another section of this document (Principle 1.4), which deals with a maximum allowable downward viewing angle.

Criterion A2: The criterion of 20 seconds as the maximum total glance time toward task-related controls and displays was derived from consideration of several factors. Green (1999) found that the number of glances to complete a secondary task was predictive of number of lane exceedences. The latter finding is not likely to be due simply to the longer time spent driving that is associated with more glances away from the road scene. For example, Tijerina, et al. (1999) found that with an interactive-voice response system for entering destinations while driving took about 75 seconds on average to complete, no (zero) lane exceedences were observed.

On the other hand, an argument can be made that some new technologies might produce many very short 'check' glances, which, individually, are not likely to be a problem. For example, a system request with a long response time might prompt the driver to use several very short (e.g., 300 ms in duration) glances to see if the response has arrived and

is displayed. Thus, limiting the number of glances when short check glances are included appears overly conservative in such an instance. Instead, a limit on total glance time to task-related controls and displays is offered.

The total glance time limit is derived from Dingus (1987) (see also Dingus et al., 1989). Table 2, from Dingus (1987), presents data regarding how mean number of glances, mean glance duration, and lane exceedences (i.e., departures from the travel lane during in-vehicle interactions) are related. These data were obtained in an instrumented vehicle driven on public roads.

The mean number of glances away from the road scene for the radio tuning task is 6.91 glances with a standard deviation of 2.39 glances (see Dingus, 1987). Assuming an approximately normal distribution, the 85th percentile for the number of glances to complete a manual radio tuning task is $6.91 + (1.04 \times 2.39)$ or 9.40. This is rounded to 10 glances for an engineering criterion in whole numbers.

The total glance time limit is derived by multiplying the engineering estimate of the 85th percentile single-glance duration with the estimate of the 85th percentile of the number of glances provided above, i.e., 2 sec x 10 glances or 20 seconds.

It should be noted that there is a significant difference between the effect on lane keeping performance associated with radio tuning and that associated with cassette tasks in Dingus (1987). A substantial difference also exists between radio tuning as compared to adjusting the power mirror. Since both cassette tasks and power mirror adjustment involve substantial manual interaction, the influence of control type (i.e. conventional control elements, touch screen, controls with active feedback, voice control, etc.) on the proposed criteria should be addressed in future research.

To summarize, this criterion has been chosen for three reasons:

1. Total device fixation time is independent of the prevailing traffic condition and reflects a driver-paced interaction. The driver chooses whether the traffic situation permits a manual-visual interaction in order to complete the secondary task.
2. Total display fixation time is more appropriate to future systems, which provide information specifically designed for in-vehicle use via the Internet, because it does not include the time spent waiting for information to download. Specifically, the driver would not view Internet pages, but may receive information retrieved via the Internet, which is then displayed in a simple, driver-friendly manner (i.e., no animation, no movies, optimal font size, etc.). Example: The driver is looking for a parking facility in his/her vicinity. This service can be started by less than four inputs.

After sending his/her request to the provider, an hourglass is shown on the display until the system receives the five nearest parking facilities. While the system is busy retrieving the information as indicated, for example, by an hour glass symbol the driver will typically perform very short “check glances” of less than 300 ms in duration, typical of the glances used to check instrumentation. After the provider has sent the list with the parking facilities, the driver can choose one and will be automatically guided by the navigation system to this goal.¹⁸

3. Total glance time generally does not exclude state-of-the-art navigation systems, some of which have been shown to have no critical influence on driving performance (see Chiang & Weir (2000)) under some real-world traffic conditions. It should also be noted that the navigation system investigated by Dingus (1987) had less influence on driving performance than manual radio tuning.

Justification for Alternative B:

The aim of principle 2.1 is to ensure that systems with visual displays are designed such that driving is not significantly degraded by completion of a secondary task. Therefore, it should always be an option to directly evaluate the impact of a new information or communication system on driving performance, instead of using the surrogate measure of eye glance behavior.

A second reason for establishing alternative B is that eye glance behavior measures (criteria A1 and A2) may not be fully indicative of overall driving performance. For example the navigation tasks reported by Dingus (1987) yielded higher visual workloads, but fewer lane exceedences than manual radio tuning. On the other hand, a task like inserting a cassette was associated with even more lane exceedences than manual radio tuning, while at the same time having less visual demand. Thus, the correlation between visual demand and disruptions of lane keeping is certainly less than perfect. Moreover, the proposed value of 20 seconds for total glance time would not allow certain navigation functions that have been found not to adversely influence driving performance more than radio tuning in some circumstances (see Chiang, Weir, 2000). Also, Tijerina (2000) reported that one of three visually-manually controlled navigation systems tested yielded an average total eyes-off-road-time of 60 seconds, but the average number of lane exceedences was the same as for manual radio tuning. In this case, the display of the navigation system (Delco) was mounted significantly closer to the driver’s normal line-of-sight while manual radio tuning was done on an aftermarket radio mounted low in the

¹⁸ Since single “check glances” have been found not to have a significant adverse effect on driving performance, they should be excluded from total glance time calculation, (Wierwille, 1993: mean transition time between the in-car task and forward view > 100 ms => 2 x transition time +short display function + 300 ms). On the other hand, to address the concern that there may be many, rather than just one or two, such check glances, multiple check glances not intervened by a control action are considered part of the visual demand of the function or feature and should be included as part of the calculation pending further research.

center stack. These results support the hypothesis that peripheral view has a significant effect on driving performance during secondary task completion. This is a primary motivation for a separate principle to address the maximum allowable down-angle for visually intensive displays (Principle 1.4). Ongoing and future research is expected to confirm this effect. The influence of the display position and the position of controls is not taken into account by the proposed criteria of A1 and A2.

Since the allowable absolute influence of a secondary task on driving performance is very difficult to define, a relative comparison with a reference task is used again. As an interim solution, specific reference tasks and devices are specified in the Verification Procedures for Alternative B, below. In the future, a range of representative tasks will be specified to ensure the range of possible controls and mounting positions to be evaluated are appropriately represented by the reference task.

Safety-relevant criteria of driving performance in a real-world driving context (including speed and lane changes of lead- or other vehicles) are:

1. *Lateral- position control: lane keeping:*

The number of lane exceedences occurring during one test trial reflects the subject's ability to anticipate the future vehicle path and to make precise corrections. In order to evaluate the influence of a new in-vehicle device on driving performance, the distributions of extent and integral of lane exceedences for a group of test participants is statistically compared for driving while interacting with a new secondary task to the distribution under reference task conditions.

A lane exceedence is defined by the condition that one of the vehicle's tires exceeds the outside edge of the lane marker (see figure 2).

Figure 2: Definition of lane exceedence

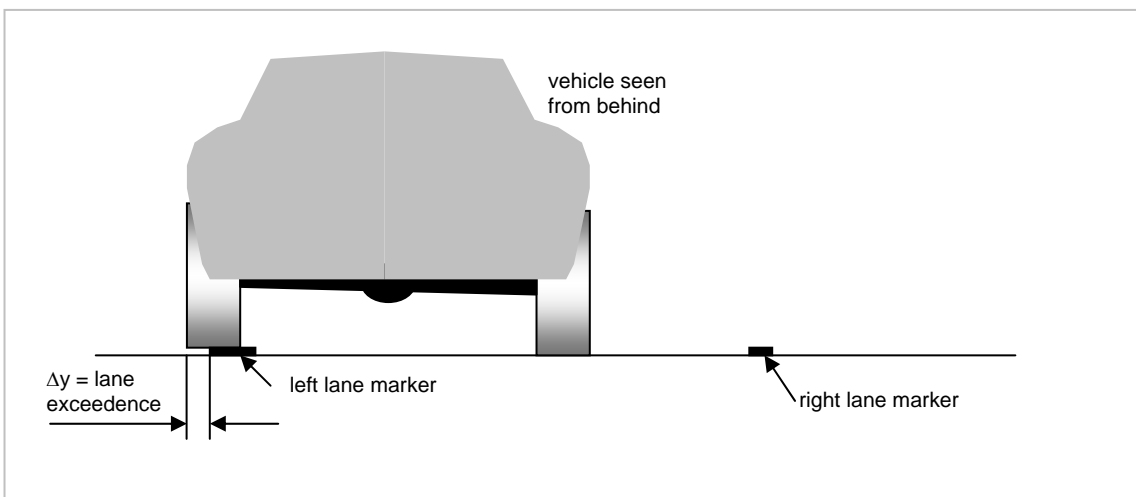

2. *Following headway:*

Maintaining an adequate separation between one's own vehicle and other vehicles reflects the ability of the driver to react to speed changes of lead vehicles or lane-changes of other vehicles. In car following, inter-vehicle separation is characterized in terms of the inter-vehicle range, range-rate, and velocities. Car-following headway is calculated as the inter-vehicle range divided by the subject vehicle velocity to produce a measurement in units of seconds. Adaptive Cruise Control systems available today operate in a range between about 1 and 2.5 seconds. Again the distributions of car following headway variability are statistically compared for both conditions.

Alternative criteria could be established by analyzing the maximum longitudinal and lateral accelerations that occur during an accident avoidance maneuver. Again, the evaluation of a new secondary task is based on statistical comparison of the number and values of these criteria for secondary task conditions to reference task conditions.

In order to assure validity and repeatability, a standard driving context, the reference task, the characteristics and instruction of the test participants, as well as the data collection, data analysis procedure and interpretation, must be defined. This is true for on-road tests as well as for driving simulator experiments.

Verification Procedures

Note: Work currently is underway to determine a statistically derived acceptance-sampling plan. This acceptance-sampling plan will be used to determine the sample size needed to manage both Type I (false positive) and Type II (false negative) risks.

Both alternatives A and B necessitate the definition of a standard driving context. A standard driving context for data collection can be matched to a driving profile for distraction-related crashes, generally (e.g., Stutts, et al, 2001; Hendricks, Fell, and Friedman, 2001). From the crash record, the following driving conditions appear to be appropriate:

- on a divided roadway;
- at posted speed 45 mph or below;
- in daylight;
- on dry pavement; and

- with low to moderate traffic density.

A ride-along observer or evaluator may be needed to request or prompt tasks and monitor the equipment needed for data collection. Use of an in-vehicle observer should be carefully managed since s/he can cause additional workload on the subject driver (i.e., the feeling that the session is a driving lesson). For example, conversation between the observer and the subject driver should be avoided, and the observation interval should begin after an extended period of driving in order to acclimate the subject driver to the presence of the observer.

As an interim solution, the following reference tasks and device are specified for the purpose of verifying conformity with alternative B of this principle.

1. Apparatus

A radio with several push-buttons and a display can be used or simulated. Figure 4 gives an example.

Controls:

- selection of radio function;
- toggle between bands (AM, FM1, FM2, weather band);
- frequency up;
- frequency down; and
- at least six additional controls which are not used for the task.

Display:

The size of the digits on the display is at least 5mm.

Position:

The radio device is mounted at a location that corresponds to the lower center stack, that is approximately 15° to the right and no more than 40° down. A position as low as 40° is appropriate for several reasons:

1. The rationale behind the reference task approach is to find a socially accepted, reasonably-demanding reference condition (in terms of driving performance, etc). Since the influence of manual radio tuning is influenced by the position of the device, the device for the reference task should be mounted near the lowest position that has been considered acceptable.
2. The criteria and values in alternative A of principle 2.1 are based on data for vehicles from the 1980s to the present. Numerous in-vehicle devices (including car radios) in

vehicles of this era have been/are positioned at or below a 40° downward viewing angle.

3. New devices mounted at 30° or higher can be easily compared with the reference task in a single setup.

Of course every company is free to choose a mounting position above 40° if this is more convenient in a given case (e.g., if a fixed mounting position above the 40° line is available in test vehicle). Note, however, that a higher position for the reference task will make the test more conservative (i.e., it will be more difficult to demonstrate that the test device does not cause more distraction than the reference task).

If a simulated radio is constructed, the following features should be incorporated:

Radio signal:

20 radio stations are simulated (WAV-Files), 10 with spoken messages, 10 with music playing.

Noise: White Noise should be used to simulate the noise between the stations.

An example for the distribution of radio stations (signal) and noise is depicted in Figure 3. Note that this distribution will be changed from trial to trial to avoid learning effects (see below).

AM 530 to 930 kHz (steps of 5 kHz, approx. 200 steps)

FM: 89 – 108 MHz (steps of 0.1 MHz, approx. 200 steps)

If a real radio is used, it should provide reasonable approximation of these features.

2. Procedure

A single task trial consists of:

- (1) selection of radio function;
- (2) selection of band; and
- (3) selection of defined frequency.

The task must be designed so that several repetitions are possible, i.e., the task should not be perfectly predictable after the first trials.

- Display on the simulated radio: “CD PLAYING,”
- The experimenter tells the participant a band and a frequency, e.g. “FM1 102.4”
- The subject presses the “Radio” button.

- The subject presses the button for band selection to find the target band.
- The subject presses either the “Frequency up” or “Frequency down” button to find the target frequency.
- One second after the target frequency has been found the radio turns silent and “CD PLAYING” is presented on the Display of the simulated radio.
- One second later the experimenter tells the subject the next target frequency (e.g. “AM 639 kHz”)

Note:

When the radio button is pressed, one band is chosen randomly, but never the target band.

When the target band is found, a start frequency is set randomly with the only restriction that it is at least 40 steps above or below the target frequency.

3. Suggestions for further reference tasks (to be specified more precisely later)

- adjust side wings (mirrors);
- use of Tape player (take tape, put in player etc.);
- input security code (PIN-No.);
- adjust sound settings within a menu structure (treble, bass, etc.); and
- possibly to include tasks that are not device-related

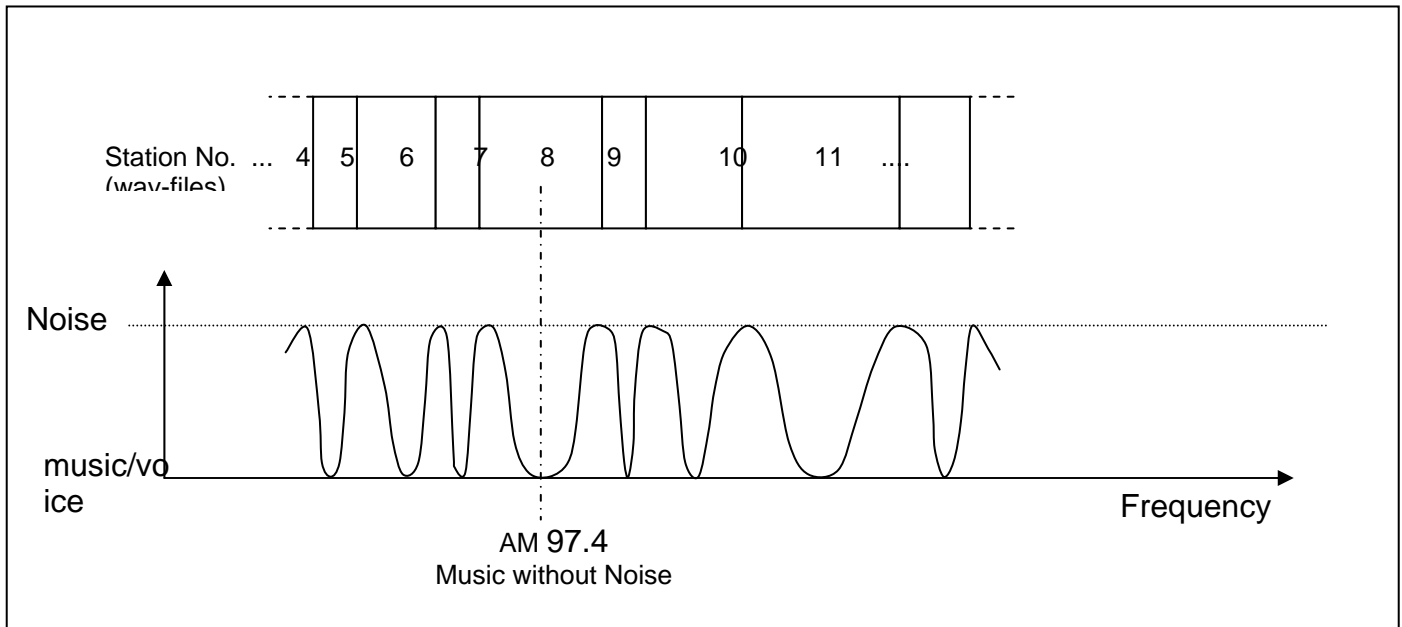

Figure 3. Distribution of radio stations and noise

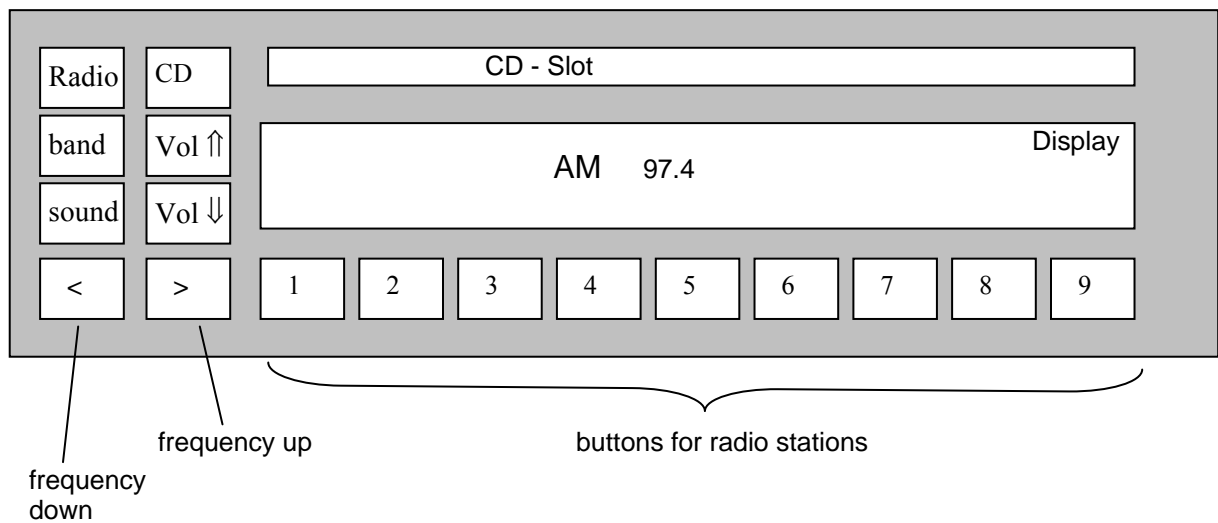

Figure 4. Example for radio

The *subjects* shall meet the following criteria:

- Test sample size should be sufficient to control for both Type I (false positive) and Type II (false negative) error risks.

- Test participants should be selected from licensed drivers who are:
 1. not familiar with the system under investigation but interested/motivated to use the system if it is sold as an option;
 2. capable of learning and completing the test procedure;
 3. evenly distributed in terms of gender; and
 4. ages between 45 and 65,
- Each test participant should be familiarized with the system in advance of testing and trained on each task to be tested. This training should include demonstration of how to perform the task, followed by at least two practice trials with feedback for the test participant prior to formal evaluations.
- Each test participant should be tested at least two times on each task.

It is of great importance that all subjects are equally *instructed* to give highest priority to driving and only to interact with the system if or when they feel comfortable doing so.¹⁹

¹⁹ Because it may not always be appropriate or even possible (i.e. in an early design stage) to carry out extensive simulator studies, test track studies, or on-road tests, and because eye glance behavior is difficult to measure, alternative evaluation methods are currently being developed.

The occlusion method, for example, does not assess eye glance behavior directly, but determines for how long and how often the driver needs to look at a display in order to carry out an interaction or series of interactions by using a shutter technique. Ongoing and future research is needed to verify the hypothesis that the impact of a secondary task on driving performance is acceptable if; 1) the visual demand per discrete interaction, or “chunk,” is low (i.e., necessary shutter open time is short); and 2) the interaction is always paced by the driver (i.e., the driver controls the shutter and is not compelled by the system to continue to a succeeding interaction on penalty of exceeding a time-out or reset period). Recent research has shown, that the occlusion method holds promise for the evaluation of information presentation on displays in terms of complexity (see Krems, Keinath, Baumann, Gelau & Bengler, 2000) and dialogue interruptability (see Keinath, Baumann, Gelau, Bengler & Krems, in press).

A second alternative evaluation method could be constituted by the Peripheral Detection Task (PDT). A method for estimating workload, Peripheral Detection, has become more popular during the last years in driver behavior research. It is based on the idea that the functional field of view is reduced with increased workload or, alternatively, that attention becomes more selective with increased workload (Miura, 1986). It has been implemented in several ways, but one method consists of presenting a light stimulus for one second at a horizontal angle between 11° and 23°, with an inter-stimulus interval of 3 to 5 seconds. The stimulus can be perceived in the peripheral field of view and does not require foveal vision. The driver responds to the stimulus by pressing a response button attached to the index finger or, i.e., by applying the brakes if the method is used in a vehicle mock-up placed in a laboratory. The percentage of missed signals and average reaction time increase with higher workload. This method is useful for measuring workload over a longer period of time (as in the case with the subjective measures), as well as for measuring variations and short lasting peaks in workload. In a number of studies, this method has shown sensitivity to small variations in workload. Some examples are workload as a function of traffic and road environment, and driving experience or HMI complexity (e.g., Van Winsum & Hoedemaeker, 2000, and Van Winsum et al., 1999). Furthermore, PDT has a functional correspondence with roadside objects. The horizontal angle at which the stimuli are presented to the driver corresponds with the location of pedestrians or road signs. If more PDT stimuli are missed because of increased workload, it may be assumed that under similar circumstances also more road signs, pedestrians or other relevant objects may be missed because of

Verification Procedure for Alternative A:

Any of the three verification procedures (described below) may be used. All would be based upon a methodology in which:

- A sample of test participants is drawn to perform tasks with the system.
- Test samples include multiple test participants sufficient to control Type I (false-positive) and Type II (false-negative) error risks.
- Test participants are neither familiar with nor knowledgeable about the system, but should be interested, motivated, and capable of learning and completing the test procedure.
- Test participants ages should be between 45 and 65 years.
- Half of the sample should be male and half female.

Each test participant should be familiarized with the system in advance of testing and trained on each task to be tested. This training should include demonstration of how to perform the task, followed by practice trials for the test participant.

- Each test participant should be tested multiple times on each task.
- A static, divided attention test²⁰ condition can be utilized for the second and third techniques below.

attentional narrowing. Because of this, the measure appears to be valid. Similar findings have been reported in different studies under similar circumstances. Thus, the method appears to be reliable.

²⁰ A divided attention static test condition would be one in which a test participant must concurrently perform two tasks – a ‘primary’ task (which may loosely mimic visual demands of monitoring a driving-like forward view) and a ‘secondary’ task (the telematics or infotainment system task of interest). There are many possible ways to implement this. It can be done in a driving simulator – but it can also be done very rapidly and inexpensively in a static lab setting. To illustrate how this might be done, suppose a test participant is seated in a mockup fitted with a to-be-tested telematics system. A video monitor could be positioned in front of the mockup in which the test participant is seated – and on it a video of a driving-like scene could play. Periodically in this scene, a visual event would appear, requiring the test participant to respond. There are many ways in which this can be done. For example, Kiefer and Angell (1993) used a ‘pedestrian-detection task.’ In this task, a ‘pedestrian’ appears in the roadway for a very brief duration (50 msec, for example). The test participant can be instructed to push a button indicating whether the pedestrian was detected (or, alternatively, can be instructed to push a right button if the pedestrian appears in the right lane and a left button if the pedestrian appears in the left lane). Speed and accuracy of responses in detecting pedestrians can be measured. During the performance of this ‘primary’ task, a command can be given to perform a secondary task (e.g., make phone call to home). Measures of glance behavior would be obtained for the secondary task. In other words, the ‘primary task’ is used just to visually load the test participant and to create a demand on the test participant to look away from the device or system and at a roadway-like scene (there are many versions of a primary task that would work for this purpose.) If a

1. Visual occlusion.

Tasks would be performed by each test participant under a condition in which visual occlusion goggles are used (or an equivalent visual occlusion technique is used).

The visual occlusion apparatus should provide translucent or opaque shutters (or equivalent means of allowing test participants to maintain light adaptation during the occlusion procedure). The occlusion apparatus must be configured so that shutter open/close cycles are fixed, with shutter open time of 1.5 sec and shutter close time of 1.0 sec.

Justification for these values is based on “the study of occlusion technique for making the static evaluation method of visual distraction” by Hashimoto, Atsumi, et al. (2001). There is consensus from Japan (JARI, JSAE, JAMA) on 1.5 sec shutter open / 1.0 sec shutter close cycle. This consensus was reached by the highest correlation between this cycle and empirical measurements of total glance time. Data (e.g., Dingus, 1988) indicate that glances to the roadway during performance of an in-vehicle task typically average less than 1 sec in length. Figure 1, from Rockwell (1998), also indicates a 1.5 sec open shutter time is approximately the mean glance duration for a reference task (radio tuning).

These shutter open/close intervals are adopted pending further research, but should not preclude other applications of visual occlusion. For example, data from Wierwille, Hulse, Fischer, and Dingus (1988) indicate that when traffic or roadway conditions vary during task performance, the length of glances to the roadway during device use can depend on driving task demands, averaging 1.2 sec under light traffic, 1.9 sec under heavy traffic, and 3.0 sec under conditions of a possible incident. This finding suggests the possibility for alterations for open/close cycle intervals. The need for additional research in this area was confirmed at the first international visual occlusion workshop held by Transport Canada in Turin, November 2001.

If a task can be successfully completed with total shutter open time ≤ 15 sec (with reasonable statistical confidence), the task would be considered to meet both criteria A1 and A2. This is based on the expectation that a task generally successfully completed within 15 seconds total shutter open time will seldom exceed the criteria A1 and A2 under real-world driving conditions.

manufacturer chooses to use this type of methodology in the evaluation of criteria A1 and A2, it is recommended that the manufacturer obtain a set of empirical data to determine that measures of glance duration and total glance time obtained in the static divided attention task that they have developed are sufficiently correlated with measures obtained from on-road driving performance (prior to using it as a verification test).

2. Eye view monitoring (and direct measurement of number and length of glances to the device per task) of task performance.

This should be done under dynamic driving conditions such as on-road or test track or in a simulator. This also may be done under static conditions such as divided attention test conditions. For each test, eye-view monitoring equipment should provide a record of glances to the in-vehicle system during task performance, as well as lengths of those glances; for each test participant. Also for each test participant, a sum of the duration of all glances to the in-vehicle system should be obtained for each test trial (total glance time per trial).

A task will be considered to meet criterion A1 if the mean of the average glance durations to perform a task is ≤ 2.0 sec for 85% of the test sample. A task will be considered to meet criterion A2 if the mean total glance time to perform a task is ≤ 20 sec for 85% of the sample of test participants.

3. Videotaping of glance behavior during task performance and extraction of measures from video.

This, too, may be done under on-road driving conditions or under static divided attention test conditions (as described above). Data on glances to the in-vehicle system during task performance under static divided attention conditions may be recorded by video. These data should include time stamping on the video, or at least a means to obtain duration information from the video record. The video should be scored with frame-by-frame analysis to obtain a record of glances to the in-vehicle system during task performance -- and lengths of those glances. (An alternative to frame-by-frame analysis also may be used, provided it has been demonstrated through empirical work to yield equivalent measurement validity.) For each test participant, on each trial, two measures should be obtained to gauge compliance with the criteria. First, the sum of the duration of all glances to the in-vehicle system (total glance time per trial) should be obtained.

A task will be considered to meet criterion A1 if the mean of the average glance durations to perform a task is ≤ 2.0 sec for 85% of the test sample. A task will be considered to meet criterion A2 if the mean total glance time to perform a task is ≤ 20 sec for 85% of the sample of test participants

Verification Procedure for Alternative B

Testing should be carried out on roads, on a test tracks, or in a driving simulator. A standard driving context has already been introduced and should be applied to any selected testing venue. If a driving simulator is used, it should be correlated with on-road data and should meet the following minimum criteria:

- visual information: The visual field should cover a sufficient range to enable the driver to realistically judge his/her vehicle's position within the travel lane and with respect to other road users.
- auditory information: In addition to simulating engine, tire, and aerodynamic sounds, the driver should be given auditory feedback when driving on a road shoulder.

The same methodological details presented earlier (e.g., sampling plan, training, instructional set, etc.) would apply to the verification procedures for alternative B.

The evaluation of a new secondary task is based on statistical comparison of the distributions across the test participants of number and the values of these criteria for secondary task conditions to reference task conditions²¹.

Examples:

No examples for this principle.

References:

Chiang, D.P., Brooks, A.M., Weir, D.H. (2001): *An Experimental Study of Destination Entry with an Example Automobile Navigation System*. SAE-paper 2001-01-0810.

Dingus, T. A. (1987): *Attentional demand evaluation for an automobile moving-map navigation system*. Unpublished doctoral dissertation, Virginia Polytechnic Institute and State University, Blacksburg, VA.

Dingus, T.A., Antin, J.F., Hulse, M.C. & Wierwille, W.W. (1989): Attentional demand requirements of an automobile moving-map navigation system. In: *Transportation Research*, A 23(4), 301-315.

Green, P. A. (1998): *Visual task demands of driver information systems*. Ann Arbor, MI: University of Michigan Transportation Research Institute.

²¹ It should be noted that the proposed measures and methods to evaluate directly the effect of a communication or information system on driving performance are currently being investigated by automotive manufacturers and research institutes. These measures and methods, including static variations, will be investigated and brought forward when the empirical work is completed.

Hashimoto, K. and Atsumi, B. (2001): Study of Occlusion Technique for Making the Static Evaluation Method of Visual Distraction, 2000 ITS World Congress, November 15, 2001.

Kiefer, R. J., & Angell, L. S. (1993): A comparison of the effects of an analog versus digital speedometer format on driver performance in a task environment similar to driving. In A. G. Gale (Ed.), *Vision in Vehicles-IV* (pp. 283-290). Amsterdam: North Holland/Elsevier.

Keinath, A., Baumann, M., Gelau, C., Bengler, K., & Krems, J.F. (in press): Occlusion as a Technique for Evaluating In-Car Displays. In: D. Harris (Ed.), *Engineering Psychology and Cognitive Ergonomics*. Vol. 5 and 6. Brookfield, VT: Ashgate.

Krems, J.F., Keinath, A., Baumann, M., Gelau, C., & Bengler, K. (2000): Evaluating Visual Display Designs in Vehicles: Advantages and Disadvantages of the Occlusion Technique. In: L.M. Camarinha-Matos, H. Afsarmanesh & H.-H. Erbe (Eds.), *Virtual Organizations, Balanced Automation, And Systems Integration*. Boston, Dodrecht, London: Kluwer Academic Publishers.

Miura, T. (1986). Coping with situational demands: A study of eye movements and peripheral vision performance. In A.G. Gale, I.D. Brown, C.M. Haslegrave, P. Smith & S.H. Taylor (Eds.) *Vision in Vehicles-II*. Amsterdam: Elsevier, North Holland.

Rockwell, T H. (1988) : Spare visual capacity in driving-revisited: new empirical results for an old idea. In a. G. Gale et al. (eds.), *Vision in vehicles II* (pp. 317-324). Amsterdam: Elsevier.

Stutts, J., Reinfurt, D., Staplin, L., and Rodgman, E. A. (2001): *The role of driver distraction in traffic crashes, Phase I Final Project Report*. Chapel Hill, NC: University of North Carolina Highway Safety Research Center. Prepared for the AAA Foundation for Traffic Safety.

Tijerina, L. (2000, July): *Driver distraction with wireless telecommunications and route guidance systems* (Report No. DOT HS 809-069): Washington, DC: National Highway Traffic Safety Administration.

Winsum, W. van, & Hoedemaeker, M. (2000). A road test of a prototype satellite system for in-vehicle menu control (Report TM-00-C003). Soesterberg, The Netherlands: TNO Human Factors

Winsum, W. van, B. Driesen, W. Huiskamp, A. Wieveen (1999). survey of technologies: Human Machine Interface, Robotics, Simulation Technology, Intelligent Transportation Systems. TNO Report 99.OR.VD.006.1/KW.

Wang, J-S., Knipling, R.R., and Goodman, M. J.(1996): The role of driver inattention in crashes: New statistics from the 1995 Crashworthiness Data System. *The 40th Annual Proceedings of the Association for the Advancement of Automotive Medicine*, October 7-9, 1998, Vancouver, British Columbia.

Wierwille, W. W. (1993): Visual and manual demands of in-car controls and displays. In B. Peacock and W. Karwowski (eds.), *Automotive Ergonomics* (pp. 299-320). London: Taylor and Francis.

Wierwille, W. W., and Tijerina, L. (1998). Modeling the relationship between driver in-vehicle demands and accident occurrence. In A. Gale, et al. (Eds.), *Vision in Vehicles VI* (pp. 233-243). Amsterdam: Elsevier.

Table 1. Sources of Distraction as reported in Wang et al. (1998) and in Stutts et al. (2001) (latter labeled as AAFTS).

Data Element	% of Drivers			
	Wang, et al.	Rank Order	AAFTS	Rank Order
Outside person, object or event	2.0	1	29.4	1
Adjusting radio, cassette, CD	1.2	2	11.4	2
Other occupant	0.9	3	10.9	3
Moving object in vehicle	0.3	4	4.3	4
Other device/object brought in vehicle	0.1	6	2.9	5
Adjusting vehicle/climate controls	0.2	5	2.8	6
Eating or drinking	0.1	.	1.7	.
Using/dialing cell phone	0.1	.	1.5	.
Smoking related	0.1	.	0.9	.
Other or unknown distraction	1.5+1.3	.	34.2	.

Figure 5

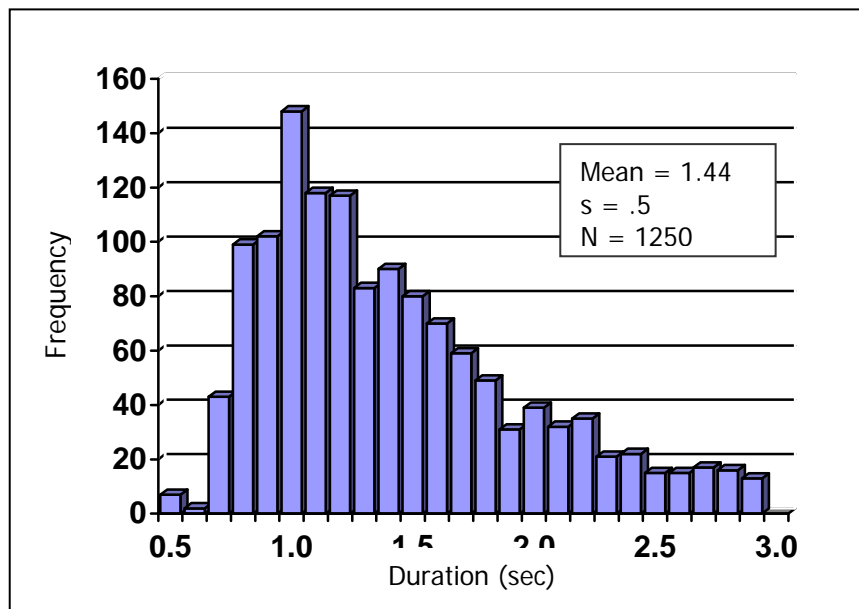

Figure 5. Distribution of eye glance durations when manually tuning a radio (Source: Rockwell, 1988).

Table 2. Mean Eye Glance Duration, Number of Lane Exceedences (out of 32 performers), and mean Number of Glances for Various In-Vehicle Tasks (Source: Dingus, 1987).

Task	M_GD	# of Lane Deviations	M_GF
Following Traffic	0.75	0	1.31
Time	0.83	0	1.26
Speed	0.62	0	1.26
Vent	0.62	0	1.83
+Destination Distance	1.06	0	1.73
+Destination Direction	1.20	0	1.31
Turn Signal	0.36	0	0.63
Fan	1.10	1	1.78
Remaining Fuel	1.04	1	1.52
Tone Controls	0.92	1	1.73
Correct Direction	1.45	1	2.04
Sentinel	1.01	2	2.51
Balance	0.86	2	2.59
Defrost	1.14	3	2.51
+Heading	1.30	3	2.76
Info Lights	0.83	3	2.12
Fuel Economy	1.14	3	2.48
+Zoom Level	1.40	4	2.91
Fuel Range	1.19	5	2.54
Temperature	1.10	8	3.18
+Cross Street	1.66	8	5.21
+Roadway Name	1.63	8	6.52
+Roadway Distance	1.53	9	5.78
Tune Radio	1.10	10	6.91
Cassette Tape	0.80	13	2.06
Power Mirror	0.86	21	6.64
M_GF = Mean Glance Frequency		+Navigation Tasks	
M_GD = Mean Glance Time			

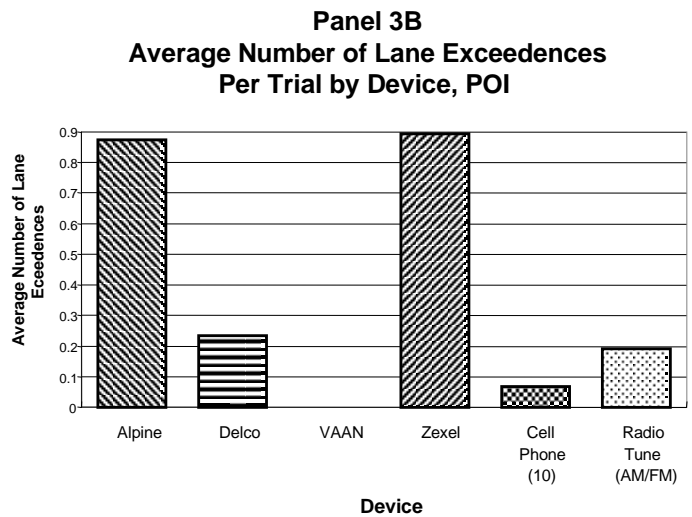
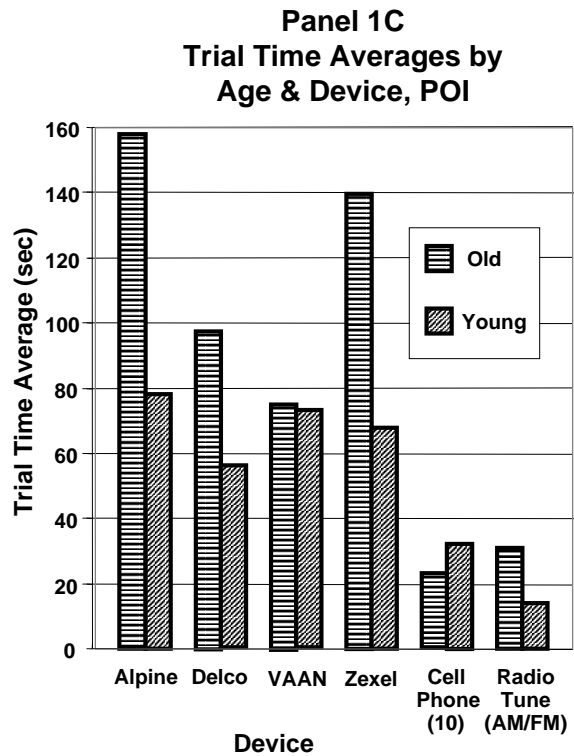

Figure 6. Task Completion Time (Trial Time) and lane exceedence data for navigation system Point-of-Interest (POI) destination entry tasks and comparison conditions. Note that VAAN represents an auditory-vocal interface (Source: Tijerina, 2000).

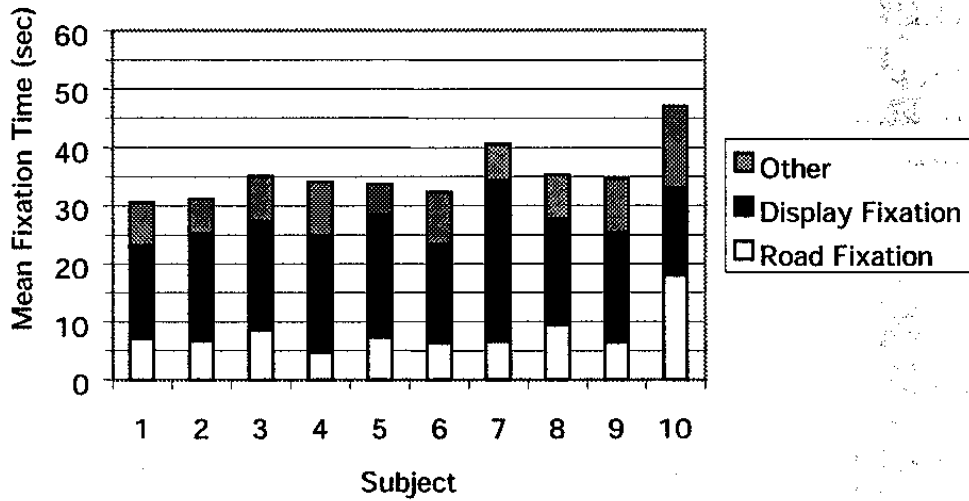

Figure 12. Total Fixation Times on City Streets (Mean of 3 Entries)

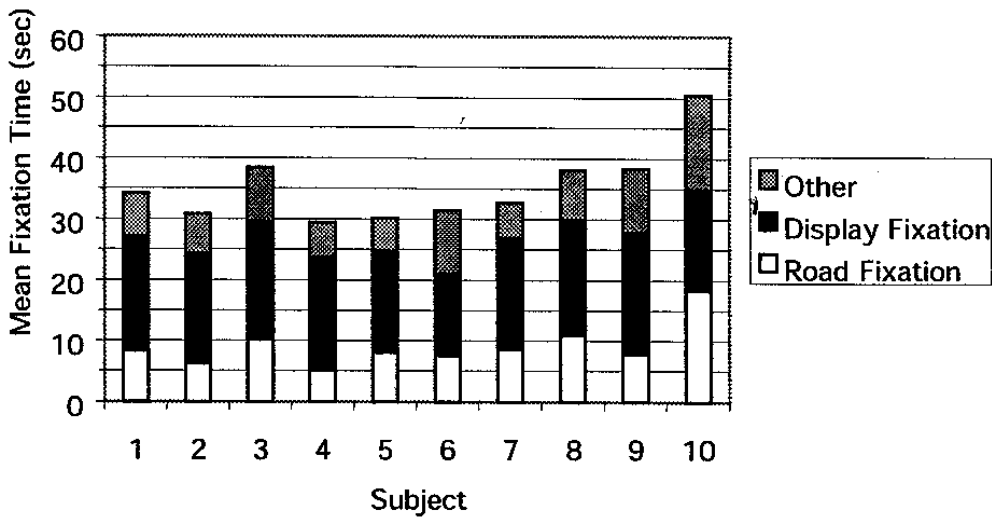

Figure 13. Total Fixation Times On Freeway (Mean Of 3 Entries)

Figure 7. Total Display Fixation Times for destination entry using a touch screen navigation system (Honda Acura) on City Streets (Figure 12) and on Freeways (Figure 13), each pillar resulting from a Mean of 3 Entries. (Source: Chiang et al. 2001)

2.2 Where appropriate, internationally agreed upon standards or recognized industry practice relating to legibility, icons, symbols, words, acronyms, or abbreviations should be used. Where no standards exist, relevant design guidelines or empirical data should be used.

Rationale:

Standards related to legibility and symbol clarity prescribe physical or geometrical characteristics for visual information intended to give displayed information the highest probability of being easily comprehended by a driver in a large range of circumstances and environments.

As regards the other items, the continuously increasing numbers of words, acronyms, and abbreviations in the environment make it necessary to adopt the most common practice.

Criterion/Criteria:

Manufacturers to design to conform with appropriate industry standards, practices or guidelines.

Verification Procedure:

Design to conform – the following are examples of industry standards or guidelines that may be applied.

Icons, Symbols, Words, Acronyms, Abbreviations:

- FMVSS 101 and CMVSS 101 – Controls and Displays
- ISO 2575 - Road Vehicles - Symbols for Controls, Indications, and Telltales.
- In-vehicle Display Icons and Other Information Elements
Campbell, J. L., Carney, C., Richman, J. B., & Lee, J. D. (2004) In-Vehicle Display Icons and Other Information Elements Volume I: Guidelines. McLean, VA: Federal Highway Administration (FHWA-RD-03-065;
<http://www.tfhrc.gov/safety/pubs/03065/index.htm>)

Campbell, J.L. (2004). In-Vehicle Display Icons and Other Information Elements: Volume II, Final Report. McLean, VA: Federal Highway Administration (FHWA-RD-03-063;
<http://www.tfhrc.gov/safety/pubs/03063/index.htm>)

Legibility:

- ISO (DIS) 15008 - Road Vehicles - Traffic Information and Control Systems (TICS). Ergonomic Aspects of In-Vehicle Information Presentation.
- ATIS/CVO Guidelines

Campbell, J. L., Carney, C., & Kantowitz, B. H. (1998). Human factors design guidelines for advanced traveler information systems (ATIS) and commercial vehicle operations (CVO). Washington D.C: Federal Highway Administration (FHWA-RD-98-057; http://www.itsdocs.fhwa.dot.gov/jpodocs/rept_mis/5q801!.htm)

It may be necessary to augment by other test protocol where the noted documents are not sufficiently developed.

Examples:

Good: All abbreviations used in the ISO 2575 standards are commonly used.

Bad: A navigation system menu uses symbols and abbreviations invented by a system manufacturer, which differ from standardized symbols and abbreviations.

2.3 Available information relevant to the driving task should be timely and accurate under routine driving conditions.

Rationale:

It is important that under routine driving conditions any information provided by a system is accurate and is given at an appropriate time such that it can be integrated easily with other existing information and cues. The new information thus enhances existing information, reduces uncertainty, and reduces hesitation concerning future decisions. If this is not the case, the driver may be overloaded, disturbed, or more prone to errors. In critical situations, however, less important information could be suppressed, in order to ensure that the driver notices more important information or to cause the driver to take a desired action.

Criterion/Criteria:

Manufacturers to design to conform to current industry practice. Vehicle manufacturers currently provide a variety of timely information to the driver from sources internal to the vehicle, e.g., engine operating temperature, oil pressure, fuel usage, and door closure status. This information is provided to the driver in a timely manner once a sensor input is received. Signal timeliness with respect to external inputs to the vehicle (e.g., traffic information and satellite-based signals) is beyond manufacturer control.

Timeliness and accuracy of information are task and subsystem specific. Hence, no single set of system level criteria can be articulated and verification can only be done at the subsystem or task level, with an evaluation against task-specific criteria.

Verification Procedure:

Design to conform and verify by appropriate means (e.g., analysis, inspection, demonstration, or test).

2.4 The system should not produce uncontrollable sound levels liable to mask warnings from within the vehicle or outside or to cause distraction or irritation.

Rationale:

Auditory information at a sound level that is too high may affect driving or road safety by masking significant and important warning sounds concerning road and vehicle safety. Therefore, auditory information needs to be designed such that the driver is not prevented from hearing interior or exterior warnings.

Criterion/Criteria:

System sound level shall demonstrate adjustability down to a fully muted level or demonstrate that there is no significant masking of audible warnings concerning road and vehicle safety.

Verification Procedure:

Design to conform, verify by appropriate means (e.g., analysis, inspection, demonstration, or test).

Examples:

As the verification procedure is straightforward, good or bad examples are not needed.

3.0 Principles on Interaction with Displays and Controls

Section 3 contains principles related to drivers' interactions with displays and controls in the dynamic use of a telematics or advanced information system operated while driving. The focus is on drivers interacting dynamically over time with systems during driving in order to carry out tasks, and this section sets forth principles and criteria that are intended to limit the intrusion of such interactions on driving performance.

Several terms, and their definitions, as well as some accompanying clarifications, are critical to the proper application of the principles, criteria, and verification procedures in this section to the evaluation of systems. These include:

System Function. A system function consists of a major grouping of related tasks, and is defined to be a broad category of activity performed by a system, for

example, Navigation. Other examples would be: Telecommunication-based services, Internet services, etc.

Task. A task is defined as a sequence of control operations (i.e., a specific method) leading to a goal at which the driver will normally persist until the goal is reached. An example is obtaining guidance from a navigation system by entering a street address using the scrolling list method until route guidance is initiated.

Goal. A goal is defined as a system state sought by a driver. Driver goals can be met through different system executions and, as such, the system states that correspond to the meeting of these driver goals can be observed and recognized (regardless of the system being operated). That is, goal achievement is defined as equivalent to achieving the system state that meets the driver's intended state, independent of the particular system being executed or method of execution.

Examples include: obtaining guidance to a particular destination; greater magnification of a map display; determining the location of a point of interest; and canceling route guidance. Note: it may be necessary to operationalize a task's end state for evaluation purposes (see "End State" definition.)

Clarification Regarding Multiple Ways To Reach A Goal: When a system provides redundant controls or multiple software-driven paths for a user to reach a goal, all design-intended paths to reach a goal should meet the principles and criteria with representative, typical tasks.

Examples:

- A navigation destination entry may be accomplished by entering a phone number, address, cross-streets, a pre-set or other stored location, etc. All of these design-intended paths to the goal must meet the principles and criteria.
- Multiple manual controls for manipulating a device may be provided. For example, a control on or next to the display, as well as on the steering wheel of a vehicle, would be considered multiple design-intended paths for reaching system goals, and must meet the principles and criteria.

Subtask: A subtask is defined as a sub-sequence of control operations that is part of a larger task sequence – and which leads to a sub-goal that represents an intermediate state in the path to the larger goal toward which the driver is working.

Sub-goal. A sub-goal is an intermediate state on the path to the goal toward which a driver is working. It is often distinguishable from a goal in two ways: (1) it is usually not a state at which the driver would be satisfied stopping, and (2) it may vary in its characteristics and/or ordering with other sub-goals across hardware/interface executions, and thus is system-dependent.

Dependent Tasks. There is a class of tasks (called “dependent tasks”) which may be distinguished from subtasks – yet cannot be initiated until another task is first completed. Their “start state” is thus dependent upon the “end state” of another (antecedent) task. However, such tasks are to be treated as tasks (rather than as subtasks) for purposes of evaluating compliance of tasks with the principles and criteria below. They can be distinguished from subtasks by examining their end state (or goal state), which will usually be a driver sought, system-independent, state. Example: After choosing a restaurant from a POI list, the driver is offered an internet function option of making a reservation at the restaurant. The dependent task of making a reservation can only be initiated following the task of selecting a restaurant within the NAV function. It is therefore a separate, dependent task.

*NOTE 1: Subtasks should **not** be treated as separate, dependent tasks. For example, entering the street name as part of the navigation destination entry is not a separate task from entering the street number; rather, these are subtasks of the same task.*

NOTE 2: The concept of “dependent tasks,” however, does have special relevance for some domains, such as that of route following using a route-guidance support system. In particular, after the wayfinding mode has been initiated (and destination entered), subsequent route-following guidance can be treated as a series of dependent tasks. For example, following the guidance from point of issuance through achievement of goal (e.g., making of the instructed turn) would be defined as a dependent task whose start state depends on having completed the prior route maneuver successfully. (Such tasks may be evaluated analytically or through engineering judgment, as appropriate.)

Start State for Task. The start of a task under test is the default start screen for the system function under which the task falls. Every task within a system function must share the same start state for purposes of evaluation for compliance with these principles and criteria. An exception is made for tasks that can only be initiated following the completion of a previous task. For these dependent tasks, the start screen would be the end of the previous task.

End State for Task. For the purpose of testing to the criteria contained in this section, the end state of a task is completion of the final manual input to achieve the driver’s goal, or as indicated by the test subject, as appropriate to accurately measure the duration of the task. This operational definition of task end state is necessary due to the fact that test systems may need to be used for evaluations (outside of a functioning vehicle and outside of functioning network-connectivity). As a result, the end state for a task is operationalized to be the completion of control inputs for the task sequence, or as indicated by the test subject, as appropriate to accurately measure the duration of the task.

Example: A destination entry task ends with the final control input that initiates wayfinding. This is an example of a task that ends with the final control input.

Transitions Between Tasks. One source of workload in a driver's interactions with an advanced information system is making transitions between tasks in different parts of the system (e.g., moving from navigation functions to radio functions). As such, for purposes of evaluating compliance with the principles and criteria below, transitions between major system functions (e.g., power-up default screen, NAV, phone, internet, radio, etc.) should be evaluated and, when evaluated, could be treated as separate "tasks." This method for determining which transitions to evaluate should help identify transitions that have high-expectation, real-world likelihood of consumer use.

Example: At system start-up, the telematics display default screen shows the audio system (*the top-level screen for the audio system function*). When evaluating a NAV task, such as destination entry, one must first evaluate the "transition task" of initiating NAV, starting at the audio system display; then one must evaluate the NAV task of destination entry starting with the first NAV display upon function initiation.

3.1 The system should allow the driver to leave at least one hand on the steering control.

Rationale:

There are driving situations that require the driver to have precise control of the vehicle's steering. This can be achieved most effectively with both hands on the steering wheel. For other driving situations, one hand on the steering wheel is acceptable momentarily, as long as the other hand is immediately available for steering if circumstances demand it. This Principle is concerned with interactions that require the driver to provide manual control inputs (e.g., using buttons or knobs). If the manual controls are not on the steering wheel, or are out of fingertip reach from the steering wheel, the driver must remove one or both hands from the wheel to undertake the interaction.

To be in accord with this principle, the system should be designed such that only one hand is needed away from the steering wheel to interact with the system, leaving one hand free to remain on the steering wheel. In addition, if one hand must be removed from the steering wheel to undertake the interaction, the other hand should not *simultaneously* be needed for interaction (e.g., for operating fingertip controls). Further, if one hand must be removed from the steering wheel to undertake an interaction, it must be physically possible for the other hand to remain on the steering control. Finally, reach to the system controls should be possible without requiring a hand to be placed through openings in the steering wheel.

Criterion/Criteria:

All tasks that require manual hand control inputs (and which can be done with the system while the vehicle is in motion) should be executable by the driver in a way that meets all of the following criteria:

3.1 (a) When some system controls are placed in locations other than on the steering wheel, no more than one hand should be required for manual input to the system at any given time during driving.

3.1 (b) When system controls are located on the steering wheel and both hands are on the steering wheel, no system tasks should require simultaneous manual inputs from both hands, except in the following condition: one of the two hands maintains only a single finger input (e.g., analogous to pressing “shift” on a keyboard).

3.1 (c) Reach to the system’s controls must allow one hand to remain on the steering wheel at all times.

3.1 (d) Reach of the whole hand through the steering wheel openings should not be required for operation of any system controls.

Verification Procedure:

3.1a - Verification may be done through analysis of the system design or through other appropriate means. A state-transition diagram of system operation, or some other representation of system states and transitions between those states should be examined in order to identify those that require hand-control inputs. This subset of transitions then should be examined to identify which operations require the driver to remove one or both hands from the steering control (to determine this, the location of the controls within the vehicle interior will be needed). Once operations requiring removal of one or both hands from the steering wheel have been identified, a count should be obtained of the number of operations requiring both hands to be removed from the steering control. If this count is equal to zero, the system complies with criterion 3.1a.

3.1b - Verification may be done through analysis of the system design or other appropriate means. A state-transition diagram of system operation, or some other representation of system states and transitions between those states, should be examined in order to identify those that require hand-control inputs. A count of how many (if any) require the driver to make *simultaneous control inputs from both hands* should be obtained. If this count is equal to zero, the system complies with criterion 3.1b. If this count is greater than zero, then each instance in which simultaneous control inputs from both hands are needed should be examined. If all of these instances are ones in which a single finger input is maintained by one of the two hands (e.g., analogous to pressing “shift” on a keyboard), then the system also complies with criterion 3.1b.

3.1c - Verification may be done through analysis (e.g., using a 3-D human modeling tool), demonstration, or other appropriate means. The analysis or demonstration should determine what percentage of able-bodied drivers within a representative sample can operate those aspects of system functionality that are designed to be used while the vehicle is in motion with at least one hand on the steering wheel at all times. If 100% of the representative sample can do so, the system complies with criterion 3.1c. Note that the analysis or demonstration should show that this reach condition is possible across the range of steering wheel displacement that is representative of routine driving conditions and across the range of control operation typical for the system. In order for the sample of drivers that is used for this analysis or demonstration to be representative, it must include females whose stature falls at the 5th percentile (but who represent a range of arm lengths from shorter to mid-range to longer) and males whose stature falls at the 95th percentile (but who similarly have a range of arm lengths).

3.1d - Verification may be done through analysis (e.g., using a 3-D human modeling tool), demonstration, or other appropriate means. The analysis or demonstration should determine that all system controls are placed in such a way that they can be reached by 100% of able-bodied drivers within a representative sample without being accessed by reaching through a steering wheel opening. The sample used for verification of 3.1c above, also may be used for verification of 3.1d, unless system controls are attached in some way to the steering column or are within fingertip reach of the steering wheel. In the case where the system uses column-mounted controls (or other control locations, such as pods that are within fingertip range of the steering wheel), the verification sample should include females with a range of hand-sizes (for fingertip reach conditions) from smaller to larger and males with a range of hand-sizes from smaller to larger.

Examples:

Good: A control device is mounted securely in a conveniently positioned holster and can be used one-handed without removal from the holster, while still keeping one hand on the steering control.

Bad: A hand-held telephone with buttons on the handset and requiring both hands to dial.

3.2 Speech-based communication systems should include provision for hands-free speaking and listening. Starting, ending, or interrupting a dialog, however, may be done manually. A hands-free provision should not require preparation by the driver that violates any other principle while the vehicle is in motion.

Rationale:

Speech communication involves a dual task situation and the communication system may have a detrimental influence on the driving activity if it requires hand-held use of any device for speaking or listening. This Principle aims to minimize additional movements and use of the driver's hands. Therefore, design solutions that require drivers to specially

equip themselves (as in kits which require installation and adjustment on the head and neck) before speaking and listening are not desirable.

Preparatory and concluding operations for communication, such as entering a telephone number and hanging-up, are not included within the scope of this Principle.

Criterion/Criteria:

Must provide a capability for hands-free operation that does not violate any other principle while the vehicle is in motion

Verification Procedure:

Design to conform; verify by appropriate means (e.g., analysis, inspection, demonstration, or test).

Examples:

Good: Loudspeakers integrated with the radio and a microphone integrated with the instrument panel or rearview mirror is provided for the driver.

Bad: The vehicle is equipped with a microphone, which can only be used while being hand-held during driving.

3.3 The system should not require uninterruptible sequences of manual/visual interactions. The driver should be able to resume an operator-interrupted sequence of manual/visual interactions with the system at the point of interruption or at another logical point in the sequence.

Rationale:

There is a human tendency to give priority to the completion of an initiated task when there are time constraints imposed on the completion of the task (i.e., if the sequence cannot be interrupted without penalty of having to repeat previous inputs). If a driver is aware that a sequence of interactions is easily resumed, there will be a greater tendency to attend to developing traffic situations in the knowledge that the system interaction can be completed without loss of driver inputs (either data or commands), or with little effort after the traffic situation has been attended to.

When the driver resumes an input sequence, he/she should be able to begin again at the point of interruption. However, it may happen that some events have made the point of interruption no longer relevant. In such cases, another logical point will be provided by the system, which will simplify the task and lessen the workload.

Prior driver inputs should be retained so the driver does not have to re-enter the same data again. Once the driver realizes that partially entered data or commands are lost when an

input sequence is interrupted, the driver may be motivated or feel compelled to continue the full input sequence, even if the driving situation requires his or her full attention.²²

Criteria:

The system should provide the following functional interface features to support task resumption:

1. With limited exceptions (see 5 below) no system-initiated loss of partial driver input (either data or command inputs) should occur automatically;
2. However, drivers may initiate system commands (e.g. CANCEL, Backspace, etc.) that erase partial driver inputs.
3. A display of previously- entered data or current system state should be provided to remind the driver of where the task was left off;
4. (a) If feasible and necessary as determined by real-world use patterns or task analysis, the system should offer help, such as an external memory aid, to assist the driver in finding the point to resume the input sequence or in determining the next action to be taken. An external memory aid includes, but is not limited to, a displayed indication of where the driver left off, a displayed indication of input required to complete the task, or an indication to aid the driver in finding where to resume the task.
(b) If appropriate, the system should provide information for a driver resuming a task (which may be displayed at the driver request) that leaves little doubt about which input needs to be provided to continue the sequence. Care should be taken to prompt the driver in a way that reduces any risk of alarm or confusion.
5. Systems may revert automatically to a previous state (i.e., after a system-defined time-out period) and return to a previous or default system state without the necessity of further user input, provided it is a low priority system state (one that does not affect wayfinding, or safety-related functions, such as sound or contrast adjustments) and the state can be reached again with low effort (e.g. a single driver input or several presses of the same button).

This Principle does not apply to system output of dynamically changing data. The system should control the display of information related to dynamic events that are not within the driver's direct control or knowledge (e.g., distance to next turn).

Verification:

Verify by inspection or demonstration.

²² It should be noted that recent research supporting an experimental method of determining system interruptability in terms of the time lost due to interruption is being developed by ISO TC22/SC13/WG8 and codified in ISO FDIS 16673.

Justification:

Loss of driver inputs (either data or command inputs) is potentially disruptive when the vehicle is in motion, because the driver may feel compelled to achieve the full sequence rather than attend to developing traffic situations. This principle does not allow loss of driver inputs for functions available while driving, except under limited circumstances as described above. The criteria are objective and readily assessed by inspection or demonstration.

Several studies have shown that there is a human tendency to look back to the roadway frequently in order to attend to developing traffic situations (Green, 1999; Rockwell, 1988). Therefore it should be possible for the driver to look back to the road, and to temporarily cease inputs to the system at some point before the end of the sequence, without a perceptible penalty.

Examples:

Good: After temporarily halting a task for a short period of time, the system does not “time-out” and revert to its initial state, but allows the driver to resume the task without having to repeat previous inputs.

Bad: After having made four separate inputs to a navigation device, each requiring several glances to first visually, then manually, locate a selection, in order to complete a task requiring seven inputs, a driver interrupts the sequence to attend to traffic; when he returns to complete the sequence, the system has erased the previous four inputs and reverted to the opening menu for the navigation function.

3.4 In general (but with specific exceptions) the driver should be able to control the pace of interaction with the system. The system should not require the driver to make time-critical responses when providing input to the system.

Systems deemed to satisfy the requirements of Principle 3.3 are deemed to provide driver pacing of interactions. However they must also meet the requirements of Principle 3.4 set forth below. Furthermore, the system should not prompt the driver for a response in a way that conveys that only one response is possible and that it must be made in an urgent, or time-critical manner:

Criteria:

1. The system should allow the driver the choice of one or more of the following:
 - Not responding to the prompt or message;
 - Delaying a response to the prompt or message; or

- Suspending system prompts or messages (turning them or the system off) for a temporary period of time (see Principle 3.6).
2. The availability of alternative choices given a system prompt or message (e.g., choices of responding, not responding, delaying response, or suspending system prompts/messages) should be clearly conveyed in one of the following ways, such that customers correctly understand the choices available at each prompt/message:
 - By the system design or operation;
 - By the prompts/messages within the system; or
 - Through customer training/education materials.
 3. In the event that the driver does not respond to a system prompt for a time period beyond a reasonable time-out, the system should default in a way that is predictable and appropriate for the task that the driver had initiated.
 4. The time at which system prompts or messages are delivered to the driver should be appropriate for the task operation.
 5. Implementation of non-time sensitive visual prompts/messages should use cues and content that distinguishes them from time-critical prompts or messages and that are consistent with the discretionary nature of the driver's response.

Justification:

The criteria above are set forth under Principle 3.4 (in addition to ensuring that a driver can control the pacing of interaction with the system, which is largely accomplished through the content under Principle 3.3, above), because it is important that a system avoid conveying a need for urgent or time-critical response from the driver for tasks that are only discretionary in nature. An example might be an incoming phone call. Its 'ring' – if an audible tone is used -- should not utilize cues that are normally reserved for warning systems. . And, ideally, the functionality of the phone system should enable the driver to attend to the road rather than take the call, should the driver decide that is necessary (e.g., allowing delay of the call or recording of messages).

If time-critical responses are required by the driver, he/she is likely to feel compelled to provide the necessary secondary system input at the possible expense of road vigilance. This effect is even more pronounced if the driver had invested significant time/effort into a sequence of interactions. In such a case, the driver will be even less willing to yield her/his attention to the roadway if the system effectively pressures him/her to continue the sequence of interactions with the device.

Verification Procedure:

Design to conform; verify by appropriate means (e.g., analysis, inspection, demonstration, or test)

3.5 The system's response (e.g., feedback, confirmation) following driver input should be timely and clearly perceptible.

Rationale:

A system that reacts as expected by the driver contributes to the reliability of the driver-system interaction. Any delayed, ambiguous, or uncertain system response may be misinterpreted, may be taken as an error by the system or by the driver, and may lead to the driver making a second input. Uncertainty about whether an input has been completed also reduces driver attention to the roadway.

The system's response applies at two levels:

- the control activation feedback level, e.g., button displacement, auditory beep; and
- the dialog level, which is the system's response to the driver's input (e.g., a recommended route).

The system's response is timely if it is clearly perceived as reacting as expected. For control activation feedback, timing should be from the moment at which the system recognizes each driver input. For the dialogue level response (which may be either the requested information, or an indication that processing is underway), the timing should be from the end of the driver's input.

Systems controlled by voice are not currently considered as within the scope of this Principle.

The systems response is clearly perceptible if it is obvious for the driver that a change has occurred in the system and that this change is the consequence of the input. If the change within the system resulting from a given input is not systematically the same but depends on one or more previous steps of the sequence, it would be advisable to provide help (on driver request).

In each of these states, inspection of the system should be done to determine whether either the driver or the system itself can do at least one of the following:

- a. Dim the displayed information,
- b. Turn off or blank the displayed information,
- c. Change the state of the display so that the dynamic, non-safety related information cannot be seen while driving, or
- d. Position or move the display so that the dynamic, non-safety-related information cannot be seen while driving.

For any tasks that involve the use of dynamic, non-safety-related information, the results of verification testing done for Principle 2.1 should be inspected to assure that its criteria have been met.

Criterion/Criteria:

The maximum system response time for a system input should not exceed 250 msec. If system response time is expected to exceed 2 seconds, a message should be displayed indicating that the system is responding.

Note: System response time criteria provided here are not intended to apply to systems controlled by voice at this time.

Justification:

The 250 msec provision is adopted to be consistent with ISO 15005.

This criterion must be balanced with other criteria for the user-interface, such as the need to protect a button or system from inadvertent actuation. Specific exceptions to the response time criterion include manual input functions that are more complicated than a simple button-press. These more complicated inputs may include push-and-hold button functions such as those used for pre-sets or changing clock settings.

Verification Procedure:

Demonstrate conformity to the specified system input response time through analytical or empirical means.

References:

ISO/FDIS 15005: TC22/SC13/WG8: Road Vehicles – Ergonomics Aspect of Transport Information and Control Systems.

3.6 Systems providing non-safety-related dynamic (i.e., moving spatially) visual information should be capable of a means by which that information is not provided to the driver.

Rationale:

Visual information that is dynamic and includes elements that move spatially on a display, can trigger a driver to look at the display (even involuntarily in some instances). Since it is important for drivers to keep their eyes on the road as much as possible, all visual information presented by systems within the scope of this document must meet Principle 2.1 (in terms of the visual demand they place on a driver). **If information is**

dynamic and is non-safety-related in content, it must not only meet Principle 2.1, but must in addition be presented in such a way that it can be dimmed, turned off, blanked, or swiveled so that it cannot be seen while driving.

Criteria:

A system presenting dynamic, non-safety-related information must meet Principle 2.1 for all tasks enabled by or associated with this information.

A system presenting dynamic, non-safety-related information must provide at least one of the following mechanisms through which either the driver or the system itself can:

- a. Dim the displayed information,
- b. Turn off or blank the displayed information,
- c. Change the state of the display so that the dynamic, non-safety-related information cannot be seen while driving, or
- d. Position or move the display so that the dynamic, non-safety-related information cannot be seen while driving.

Justification:

The criteria supporting Principle 2.1 limit the visual demand that is placed on a driver by task-based interactions with the system. For systems which present dynamic, non-safety-related information, it is necessary but not sufficient that these criteria are met for all tasks that can be carried out on the system with this information. An additional criterion should also be met. That criterion is the second one above: That either the driver or the system should have a means through which the displayed information can be dimmed, turned off, blanked, changed in state, or moved so that the dynamic, non-safety-related information cannot be seen while driving. This additional precaution is advisable because of the unique effects that rapid movement in the visual periphery can have on the triggering of glances, as well as the effects of having to search for information that has moved or changed since it was last viewed. By allowing for the information to be dimmed or in some way removed from view by either the system or the driver (through one or more of the means identified above), some additional protection from these special types of visual demand can be obtained.

Verification Procedure:

Verification should be done through inspection of the system, its states, and the dynamic, non-safety-related information that it presents, as follows:

1. System states in which dynamic non-safety-related information is presented should be identified.
2. In each of these states, inspection of the system should be done to

determine whether either the driver or the system itself can do at least one of the following:

- i. Dim the displayed information,
- ii. Turn off or blank the displayed information,
- iii. Change the state of the display so that the dynamic, non-safety related information cannot be seen while driving, or
- iv. Position or move the display so that the dynamic, non-safety-related information cannot be seen while driving.

For any tasks that involve the use of dynamic, non-safety-related information, the results of verification testing done for Principle 2.1 should be inspected to assure that its criteria have been met.

Section 4.0 System Behavior Principles

The principles and criteria in this section address system-level issues such as the following: (a) the treatment of information that must be made inaccessible during driving because of the likelihood that it will distract drivers, and (b) the provision of information about system malfunctions that could potentially affect safety.

4.1 Visual information not related to driving that is likely to distract the driver significantly (e.g., TV, video, and continuously moving images and automatically-scrolling text) should be disabled while the vehicle is in motion or should be only presented in such a way that the driver cannot see it while the vehicle is in motion.

Rationale:

This principle refers to *visual* information that is *not related to driving*. Therefore it does not apply to non-visual information or to visual information related to driving.

“Related to Driving” is interpreted as being useful in monitoring occupant status, carrying out maneuvers, or assisting in route planning. Short, scrolling lists under the control of the driver (e.g., navigation system destinations) or a video image of hard-to-see areas are not within the scope of this Principle as they relate closely to the driving task and may not be significantly distracting under routine driving conditions as covered by these principles. Also, weather information that relates to the vicinity of the car or the intended route and emergency information, such as a closed exit, or information of approaching emergency response vehicles, are considered to be related to driving.

In contrast, visual images of the interior of a building presented for the purposes of advertising are not related to driving, and should therefore not be displayed to a driver while the vehicle is in motion. (NOTE: the outside image of a building, however, may be related to driving if it is readily recognizable to the driver as a landmark and is therefore useful for navigation purposes.)

This Principle emphasizes the importance of the visual modality for safe driving and seeks to limit visual information from within the vehicle that can provide a distraction from the primary driving task.

Criterion/Criteria:

While the vehicle is in motion, the following should not be visible to the driver:

- TV;
- video not related to driving;
- games and other dynamic images; or
- detailed images such as the interior of a building or a product.

Some examples are identified in the list above. Non-stipulated items shall be determined individually, consistent with the basic principles of this document.

Justification:

Evident from previous sections.

Verification Procedure:

Demonstrate that when the vehicle is in motion, dynamic visual information of the type listed in the criteria above, which is not related to driving, is not visible to the driver. Vehicle in motion should be interpreted as a speed that is greater than or equal to 5 mph.

Examples:

No examples for this principle.

References:

JAMA Guidelines (ver 2.1, dated February 2000) “Commentary” section.

4.2(a) System functions not intended to be used by the driver while driving should be made inaccessible for the purpose of driver interaction while the vehicle is in motion.

(b) The system should clearly distinguish between those aspects of the system, which are intended for use by the driver while driving, and those aspects (e.g., specific functions, menus, etc) that are not intended to be used while driving.

Rationale:

System functions not intended to be used by the driver while driving are those functions designated as such by the manufacturer of the system. This Principle seeks to ensure

clarity, particularly for the driver, in terms of the manufacturer's intention for use of the system. If this Principle is complied with, subsequent use of the system not within the envelope of intended use can be considered as misuse, and the driver is responsible for the consequences.

Criterion/Criteria:

- a) System design to demonstrate that functions intended to be inaccessible to the driver when driving are inaccessible and,
- b) System to clearly distinguish between those aspects of the system that are intended for use while driving and those that are not.

Verification Procedure:

Design to conform and verify by appropriate means (e.g., analysis, inspection, demonstration, or test).

4.3 Information about current status, and any detected malfunction, within the system that is likely to have an adverse impact on safety should be presented to the driver.

Rationale:

There can be negative safety implications when there is a divergence between the actual function of a system and the driver's reasonable expectations based on previous information or experience. Therefore, a change in status or a malfunction that modifies system performance should be made apparent to the driver. The aim is to ensure that the driver has access to important information about the system that can assist in predicting the effects of different driver actions, particularly on vehicle control and maneuvering with respect to other traffic and road infrastructure. This principle is particularly important for feature-rich systems, for which status indicators may be able to substantially increase the ease with which the system can be monitored or used.

Criterion/Criteria:

Manufacturers are to design to conform to current industry practice.

Justification:

Vehicle manufacturers currently provide status/malfunction information to drivers on a variety of vehicle systems, e.g., air bag restraints, ABS braking systems, hydraulic brake system, and tire pressure monitoring. Such design practice will be applied to any detected malfunction within the system that is likely to have an adverse impact on safety.

Verification:

Design to conform and verify by appropriate means (e.g., analysis, inspection, demonstration, or test).

Section 5.0 Principles on Information About the System

The principles in this section address the provision of instructions to customers on the use of systems covered by this document, including information on safety and safety-relevant installation/maintenance, as well as other representations of system use with which the customer may have contact.

5.1 The system should have adequate instructions for the driver covering proper use and safety-relevant aspects of installation and maintenance.

5.2 Safety instructions should be correct and simple.

5.3 System instructions should be in a language or form designed to be understood by drivers in accordance with mandated or accepted regional practice.

5.4 The instructions should distinguish clearly between those aspects of the system that are intended for use by the driver while driving, and those aspects (e.g., specific functions, menus, etc) that are not intended to be used while driving.

5.5 Product information should make it clear if special skills are required to use the system or if the product is unsuitable for particular users.

5.6 Representations of system use (e.g., descriptions, photographs, and sketches) provided to the customer with the system should neither create unrealistic expectations on the part of potential users, nor encourage unsafe or illegal use.

Rationale:

To ensure that instructions are of use to as many drivers as possible and that drivers are aware of the capabilities and limitations of the system, its context of use, etc., different forms of instructions may exist which could be presented in different modalities. Auditory instructions may be spoken or presented by noises or earcons. Visually-presented information includes diagrams, photographs, highlighting of the next element, programmed tutorials, etc.

These principles require that when instructions are being devised, consideration is given to the intended and likely driver population and that instructions are designed that are likely to be understood by, and to be of use to, as many drivers as possible. Diagrams

often provide additional clarity. Where used, these should follow accepted stereotypes and conventions for the intended population.

Many information and communication systems will be designed such that all functions can be used by the driver while driving. This should be clearly stated within the instructions. Other systems, generally those that are more feature-rich, may contain aspects that the manufacturer has not designed to be used while driving. Examples could include the pre-programming of stored telephone numbers. When such functions are disabled while the vehicle is in motion, this should be explained in the instructions. After becoming aware of the instructions, reasonable drivers should be in no doubt about which aspects of the system have been designed to be used by the driver while driving (i.e., the intended use of the system). They should also be in no doubt about those aspects that have not been designed for use while driving.

The normal presumption is that a system can be used by all drivers. Initial training, however, may be required for some systems such as those designed for specialist professional use. Although all drivers are required to have a minimum level of (distance) vision, other capabilities may vary considerably and this includes the capabilities of drivers with special needs.

The need for special skills and the unsuitability for particular user groups are matters for definition by the system manufacturers. If the manufacturer envisions any special skill requirement or initial training, then all product information should make this clear. Similarly, any restriction on use intended by the manufacturer should be described in the product information. For example, perhaps only some drivers will be able to use the full functionality of the system.

Annex #1

GLOSSARY of TERMS

Accurate information is sufficiently correct and has the degree of precision that the driver needs to deal adequately with the situation.

Allocation of driver attention implies that the driver has a limited available “resource” of physical and mental capacity, which can be distributed dynamically by the driver among multiple tasks.

Attentional demand is the physical and mental “resource” required at any instant to successfully perform a particular task.

Close as practicable means as close as possible taking account of engineering constraints (which might be technical or financial). These constraints might include:

- the requirement not to obstruct other controls or displays;
- the requirement for the display to be sufficiently far from the driver so there are no focusing difficulties;
- the requirement not to obstruct the roadway;
- the requirement that the display should not itself be substantially obstructed by, for example, controls such as the steering wheel or gearshift lever; or
- the requirement to place other displays with more safety critical or more important information closer to the normal line of sight.

Continuously moving images and automatically scrolling text cover a variety of forms of dynamic presentation where the driver is not able to pace the presentation and where the entire information is not available at any one time.

Dependent Tasks. There are a class of tasks (called “dependent tasks”) which may be distinguished from subtasks – yet cannot be initiated until another task is first completed. Their “start state” is thus dependent upon the “end state” of another (antecedent) task. However, such tasks are to be treated as tasks (rather than as subtasks) for purposes of evaluating compliance of tasks with the principles and criteria in this document. They can be distinguished from subtasks by examining their end state (or goal state), which will usually be a driver-sought, system-independent, state. Example: After choosing a restaurant from a POI list, the driver is offered an internet function option of making a reservation at the restaurant. The dependent task of making a reservation can only be initiated following the task of selecting a restaurant within the NAV function. It is therefore a separate, dependent task.

*NOTE 1: Subtasks should **not** be treated as separate, dependent tasks. For example, entering the street name as part of the navigation destination entry is not a separate task from entering the street number; rather, these are subtasks of the same task.*

NOTE 2: The concept of “dependent tasks,” however, does have special relevance for some domains, such as that of route following using a route-guidance support system. In particular, after the wayfinding mode has been initiated (and destination entered), subsequent route-following guidance can be treated as a series of dependent tasks. For example, following the guidance from point of issuance through achievement of goal (e.g., making of the instructed turn) would be defined as a dependent task whose start state depends on having completed the prior route maneuver successfully. (Such tasks may be evaluated analytically or through engineering judgment, as appropriate.)

Design is the process of conceiving and recording an intended purpose and physical form for a system.

Display is a device that presents information to the driver. Examples include visual displays (such as LCD screens and control labels), auditory displays (such as tones), and tactile displays (such as a haptic display).

Distraction is the capture of significant driver attention by stimulations that can arise from non-driving relevant information or from driving relevant information presented in such a way that the stimulation attracts more driver attention than strictly necessary just to obtain the relevant information. Distraction occurs when there are modes of presentation where the information has a dynamic or unpredictable component such that the entirety of information presented cannot be obtained by the driver with a series of brief glances.

Driver’s view is that mandatory minimum requirement in accordance with FMVSS 103, 104, and 111. It should be interpreted as pertaining to the forward view directly through the windshield, side views and indirect rear view via the vehicle mirror system.

Driving is adversely affected when the driver is distracted or overloaded such that their actions, or lack of actions, significantly increase the risk of an accident.

Dynamic visual information refers to images, whether textual or pictorially, moving spatially within the display.

End State for Task means, for the purpose of testing to the criteria contained in this section, the completion of the final manual input to achieve the driver’s goal, or as indicated by the test subject, as appropriate to accurately measure the duration of the task. This operational definition of task end state is necessary due to the fact that test systems may need to be used for evaluations (outside of a functioning vehicle and outside of functioning network-connectivity). As a result, the end state for a task is operationalized to be the completion of control inputs for the task sequence, or as indicated by the test subject, as appropriate to accurately measure the duration of the task.

Entertainment is a pleasurable experience arising from a voluntary or involuntary use of mental resources to process the stimulation. It results in physical or mental resources being engaged in such a way that other tasks may be temporarily forgotten or performed inattentively.

Fitting means the task of physically positioning and mechanically fixing the system with all wiring or other connections required before use.

Glance can be defined (ref: ISO 15007, SAE J2396) as the time from the moment at which the direction of gaze moves to a target to the moment it moves away from that target. This includes the transition time to or from the target (but not both) and the dwell time on the target.

Glare is the distracting (and potentially disabling) effect of bright light in an otherwise relatively dark environment, which interferes with visual acuity. In the in-vehicle context, this can occur in a number of ways, e.g.,

- external light (usually sunlight) falls on the visual display reducing display contrast and makes the information on the screen more difficult to see from the driver's normal viewing position, or
- the display is itself too bright and causes distraction from the roadway and other in-vehicle displays and controls. This is most likely to be apparent to the driver in low ambient light conditions.

Goal is defined as a system state sought by a driver. Driver goals can be met through different system executions and, as such, the system states that correspond to the meeting of these driver goals can be observed and recognized (regardless of the system being operated). That is, goal achievement is defined as equivalent to achieving the system state that meets the driver's intended state, independent of the particular system being executed or method of execution. Examples include: obtaining guidance to a particular destination; greater magnification of a map display; determining the location of a point of interest; and canceling route guidance. Note: it may be necessary to operationalize a task's end state for evaluation purposes (see "End State" definition.)

Hands-free means that there is no need to hold with the hand any component of the system. "Push-to-talk" buttons that are in a fixed location are acceptable when such devices permit the driver to react immediately when the driving situation requires it.

Inaccessible means that the designated system function is not operable by the driver while the vehicle is in motion.

Information has two types:

System information is any message presented by the system that is intended to impart some knowledge to the driver and that is conveyed by means of a display (e.g., a visual or auditory display).

Documentation information is written instructions, warnings, explanations, diagrams, etc, that are provided to customers with the device or vehicle to explain a device or system covered by these guidelines.

Information not related to driving includes news, entertainment, and advertising. News concerning a new propulsion technology, stock performance of a vehicle manufacturer, or NASCAR lap times, while connected with driving, are not concerned with the driver's immediate task or journey and so are "not related to driving" for the purpose of Principle 4.1.

Information related/relevant to driving covers information on aspects of the vehicle that are mandatory or which are related to safety or which are related to the road and traffic environment and driver related infrastructure services. Examples include:

- tire and brake parameters;
- proximity of other vehicles;
- route guidance;
- congestion information;
- ice warning;
- speed limits; and
- parking information.

Input to the system means a control action by the driver that causes a specific piece of information to be entered into a system covered by these Principles. However, the Principles do not cover driver use of primary driving controls, such as braking and steering, that may also provide inputs to the system.

Installation covers the choice of physical position (location) as well as fitting.

Interaction refers to input by a control action to the system, either at the driver's initiative or as a response to displayed information initiated by the system itself. Depending on the type of task and the goal, the interaction may be elementary or more complex.

Intermittent sounds are such that the interval between them is long enough for warnings to be received by the driver.

Interruption occurs when the driver decides not to provide input to the system at some point before the end of a sequence of interactions required to complete a task. A sequence of interactions is a related set of successive inputs/outputs also called a dialog, e.g., entering a new destination or a phone number, memorizing a radio station. A sequence of

interactions is interruptible if the driver has the possibility of restarting (within a “time-out period”) after an interruption at the place where the interruption was made or at another logical point in the sequence.

Irritation is an emotional response of annoyance or frustration as a result of persistent or frequently repetitive stimulation that is redundant or systematically at variance with the driver’s expectations. This may be caused when the same message is repeated many times, when it arrives too late, when it is perceived as irrelevant, when it is unclear, difficult to understand, uninformative, etc.

Line of sight is the direction of the driver’s gaze out of the front windshield onto the road ahead. This is close to horizontal.

Location means the physical position in space that the system occupies within the vehicle during use by the driver. The position may be:

- moveable over a pre-determined range (for systems that have an adjustable position by means of cable, stalk, or bracket, for example);
- not-fixed and intended for hand-held operation. This applies to systems that are intended to be used ”hand-held” such as remote control devices;
- not-fixed such as a system loose on a seat; or
- fixed or immovable.

Logical point is the step of the sequence chosen by the system (or at the discretion of the driver) that is relevant to the current context. This context may depend on the system state at the time of resumption, on the speed of the vehicle or its position, or on external events, etc.

Malfunction is any departure from the expected range of operation during system use as intended by the manufacturer.

Obstruct means to impede the driver’s view of the roadway, controls, displays, or access to controls.

Obstruction of the roadway means to impede the driver’s view such that conformity to relevant standards or regulations is not possible. Relevant FMVSS include 103-Windshield defrost/defog, 104-Windshield Wash-Wipe, and 111-Rear View Mirrors.

Obstruction of controls in this context means to prevent operation, or render significantly more difficult to identify, reach, or operate the relevant controls throughout their intended range of movement.

Obstruction of display(s) in this context means to render not visible from the drivers’ normal seating position a significant portion of the display(s).

Pace of interaction refers to the rate at which the driver makes an input at any step of a sequence in the time allotted by the system to the driver for making such an input, as well as to the time during which outputs are displayed by the system before being automatically cancelled or deleted after a time-out period

Primary driving task means all those activities that the driver has to undertake while driving, navigating, maneuvering, and controlling a vehicle, including steering, braking, shifting, and accelerating.

Reasonably foreseeable misuse is the use of a product, process, or service under conditions or for purposes not intended by the manufacturer, but which can reasonably happen, induced by the product, process, or service in combination with, or as a result of, common human behavior. In this context, it would not be reasonable for a manufacturer to anticipate that a driver would undertake sophisticated technical measures to defeat the manufacturer's intentions. It would, however, be reasonable for a manufacturer to foresee the possibility of a driver re-positioning a video display intended for use by rear seat passenger only, so that it could be viewed while driving, if the adjustable range allows for this. This is an engineering, not legal, definition and limited to these guidelines only.

Reflection is the generation of a secondary image of an object as a result of light from the object bouncing off intermediate surfaces. This is relevant in at least two ways:

- a) light from a light emitting display travels to another surface (or via several surfaces) producing a secondary image of the display screen; for example, on the windshield. This is most likely to be perceived by the driver when there is high contrast between the secondary image and its background, such as against the windshield during darkness; or
- b) light from an external source (e.g., the sun, streetlights, or other bright objects) is reflected by the display surface into the driver's eyes. (See, also, "glare", above.)

Required controls are those relevant for undertaking the primary driving task and all controls that are mandatory. Required controls include accelerator, brake, clutch (if applicable), steering wheel, gearshift, parking brake, horn, light switches, turn indicators, washers and wipers (all modes and speeds), hazard flashers, and defogger controls.

Required displays are those relevant for undertaking the primary driving task and all those that are mandatory. Required displays include the speedometer, all warning lights, mandatory control labels, and mandatory signals (FMVSS and CMVSS).

Responses include actions made by the driver as a feedback to the system, as well as system states given either as a direct input, or as a result of system function (e.g., generation of real-time messages).

Resume means to take up the dialog again with the same system after a period of time spent by the driver doing other things (even if this involves initiation of an interaction with another system).

Routine driving conditions means driving conditions that are *not* exceptionally demanding due to external factors, such as inclement weather, dense traffic, hazardous road (e.g., curvy, mountainous, cliff-hugging), construction, or due to internal factors such as use of other devices, eating, grooming, searching for street signs, following another vehicle in an unfamiliar area, emotional stress, etc.

Safety-related information is information that assists the driver in avoiding or reducing the risk of an immediate or imminent hazardous situation.

Speech-Based Communication Systems include telephone and radio communications. (Systems controlled by voice are not currently considered as within the scope of these Principles.)

Start State for Task under test is the default start screen for the system function under which the task falls. Every task within a system function must share the same start state for purposes of evaluation for compliance with these principles and criteria. An exception is made for tasks that can only be initiated following the completion of a previous task. For these dependent tasks, the start screen would be the end of the previous task.

Status is the available and/or active system mode(s) and state(s). A mode is a specified sub-set of system functions or behavior pattern (e.g., "processing").

Sub-goal is an intermediate state on the path to the goal toward which a driver is working. It is often distinguishable from a goal in two ways: (1) it is usually not a state at which the driver would be satisfied stopping, and (2) it may vary in its characteristics and/or ordering with other sub-goals across hardware/interface executions, and thus is system-dependent.

Subtask is defined as a sub-sequence of control operations that is part of a larger task sequence – and which leads to a sub-goal that represents an intermediate state in the path to the larger goal toward which the driver is working.

*NOTE: Subtasks should **not** be treated as separate, dependent tasks. For example, entering the street name as part of the navigation destination entry is not a separate task from entering the street number; rather, these are subtasks of the same task.*

System includes all components with which the manufacturer intends the driver to interact whether stand-alone or integrated into another system.

System Function consists of a major grouping of related tasks, and is defined to be a broad category of activity performed by a system, for example, Navigation. Other examples would be: Telecommunication-based services, Internet services, etc.

System functions not intended to be used by the driver while driving are those functions designated as such by the manufacturer of the system.

Task is defined as a sequence of control operations (i.e., a specific method) leading to a goal at which the driver will normally persist until the goal is reached. Example: Obtaining guidance by entering a street address using the scrolling list method until route guidance is initiated.

Time critical responses are responses that must be made by the driver within a short system-imposed time period.

Timely is to be interpreted here as the time frame which is most appropriate to help the driver to deal adequately with the situation.

Transitions between Tasks. One source of workload in a driver's interactions with an advanced information system is making transitions between tasks in different parts of the system (e.g., moving from navigation functions to radio functions). As such, for purposes of evaluating compliance with the principles transitions between major system functions (e.g., power-up default screen, NAV, phone, internet, radio, etc.) should be evaluated and, when evaluated, may be treated as separate "tasks." This method for determining which transitions to evaluate should help identify transitions that have high-expectation, real-world likelihood of consumer use. *Example: At system start-up, the telematics display default screen shows the audio system (the top-level screen for the audio system function). When evaluating a NAV task, such as destination entry, one must evaluate the "transition task" of initiating NAV, starting at the audio system display; one must evaluate the NAV task of destination entry starting with the first NAV display upon function initiation. The transition task and the destination task may either be evaluated as separate tasks or as a single task.*

TV means a television showing an entertainment or advertising program received via a broadcast or closed-circuit connection.

Unintended use means use of system functions not intended (by the manufacturer) to be used by the driver while driving.

Uninterruptible sequence of interactions occurs when the driver does not have the possibility of restarting (within a "time-out period") after an interruption at the place where the interruption was made or at another logical point in the sequence.

Vehicle in motion should be interpreted as a speed that is greater than or equal to 5 mph.

Video refers to entertainment or advertising programming generated from pre-recorded images and includes video games.

Visual information is graphical, pictorial, textual, or other messages presented to the driver using the visual modality.

Warning refers to a system-generated message or indication intended to alert the driver to a failure or danger, as well as to information or advice provided with a system concerning the negative consequences of a situation or action.

End of the Document